

# UTF 4240 TX, UTF 4250 TX, UTF 4240 RX and UTF 4250 RX

Optical Video Transmitters/Receivers Single-mode

## USER MANUAL

### WARNING

This is a Class A product. In a domestic environment this product may cause radio interference, in which case the user may be required to take adequate measures. Please read section 6 of this Manual

## 1. General description

This user manual is valid for the following models:

Model	Description	Housing
UTF4240 TX-SA	Transmitter 2sm	Stand-alone
UTF4250 TX-SA	Transmitter 1sm	Stand-alone
UTF 4240 TX-2	Transmitter 2sm	Rack-mounted
UTF 4250 TX-2	Transmitter 1sm	Rack-mounted
UTF 4240 RX	Receiver 2sm	Rack-mounted
UTF 4250 RX	Receiver 1sm	Rack-mounted
UTF 4240 RX-2	Receiver 2sm	Rack-mounted
UTF 4250 RX-2	Receiver 1sm	Rack-mounted
UTF 42xx /SA		Stand-alone

Table 1. Models described in this user manual  
sm = single-mode fiber

A UTF (Up the Fiber™) transmitter (TX) converts a composite video signal into a high-quality, 9-bit digitised optical equivalent and transmits this over optical fiber. Additionally, it optically receives and transmits data signals and converts these signals into electrical equivalents. Finally, the transmitter provides a voltage-free alarm contact (normally open) for door contacts and anti-tamper contacts, for example.

Complementary UTF receivers (RX) receive and convert the optical signal to video/data/contact closure. Like the TX, the RX is a bidirectional optical data transceiver.

The receivers and transmitters operate over two single-mode optical fibers or one single-mode optical fiber using either one wavelength (1310 nm) or two wavelengths (1310/1550 nm), respectively.

The bidirectional RS-485/422 data interface handles PTZ communication for all types of camera interfaces (RS-485, TTY, Manchester, biphase, Sensornet, etc.). The data interface configuration (four-wire or two-wire) only needs to be set at the receiver side.

A wide range of operating temperatures makes the stand-alone transmitter suitable for use within outdoor camera housings and camera connection boxes (see Technical Specifications).

The transmitter can be powered by the camera power supply (12 Vdc or 24 Vac) or by a PSA/PSU 12 DC. For operation under extreme environmental conditions, the PSU 12 DC is recommended.

### If 24 Vac is used, read section 3 first.

The UTF receiver (RX) is designed for use in a TKH Security MC power supply rack. The UTF 42xx/SA are the stand-alone versions of the rack-mounted models. Depending on type, they handle one (RX) or two (RX-2) video/data/CC channels.

The UTF receivers are SNM compatible.

### EasyC-s™

The receiver supports EasyC-s™. With this feature, a group of receivers only needs one external data connection. The data is put on the internal databus (D-bus) of the rack and is available to all connected receivers in that rack

The general connection layout is given in figure 1.

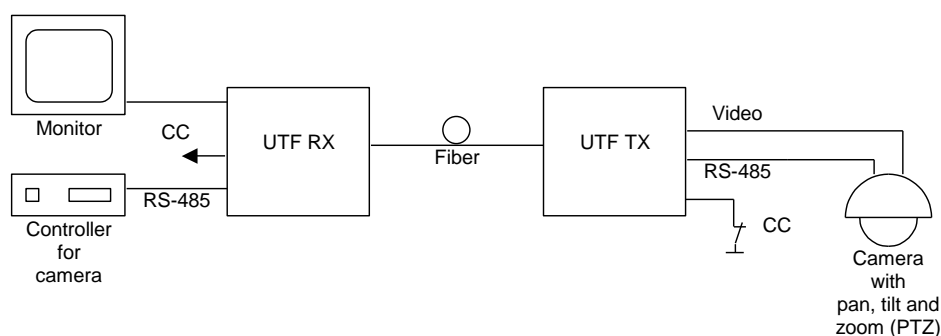

Figure 1.  
UTF general connection

## 2. Indicators and connectors

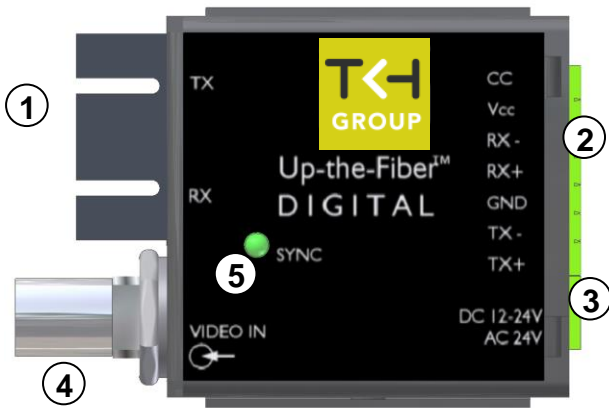

Figure 2.  
Indications and connectors on the miniature UTF transmitter (stand-alone)

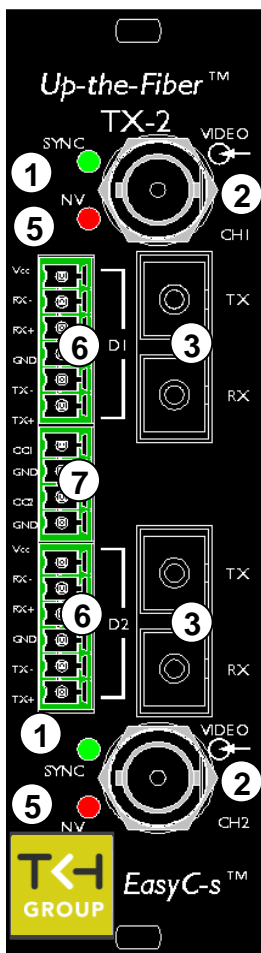

Figure 3.  
Indications and connections on the UTF transmitter\*

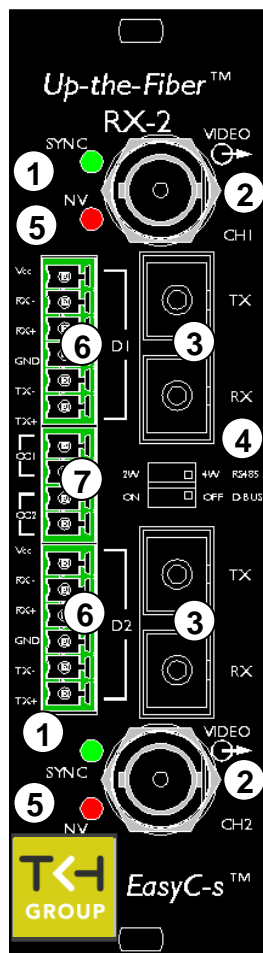

Figure 4.  
Indications and connections on the UTF receiver

### Transmitter\*

The miniature stand-alone UTF transmitter has the following indicators and connectors (figure 2):

- 1: TX: Optical fiber connection (one/two-fiber models)
- RX: Optical fiber connection (two-fiber models)
- 2: 7-Pin data connector
- 3: 2-Pin power supply connector
- 4: BNC 75 Ω connector: Composite video input
- 5: SYNC: This indicator can show:
  - Green: Operational link;
  - Red: Local synchronisation error;
  - Yellow: Remote synchronisation error.

The rack-mounted UTF transmitter has the following indicators and connections (figure 3):

- 1: SYNC: This LED can show:
  - Green: Operational link;
  - Red: Local synchronisation error;
  - Yellow: Remote synchronisation error.
- 2: BNC 75 Ω connector: Composite video output
- 3: TX: Connection for optical fiber (one/two-fiber models)
- RX: Connection for optical fiber (two-fiber models)
- 4: Not used
- 5: NV: This LED can show:
  - Red: No video on in- or output;
  - Off: Video signal present.
- 6: 6-Pin data connector
- 7: 4-Pin connector for potential-free alarm contacts (channel CC1/GND and channel CC2/GND).

\*Note that the TX 4240 is no longer available.  
The TX 4250 is only available upon special request.

### Receiver

The UTF receiver has the following indicators and connections (figure 4):

- 1: SYNC: This LED can show:
  - Green: Operational link;
  - Red: Local synchronisation error;
  - Yellow: Remote synchronisation error.
- 2: BNC 75 Ω connector: composite video output
- 3: TX: Connection for optical fiber (one/two-fiber models)
- RX: Connection for optical fiber (two-fiber models)
- 4: Dual toggle switches for 4-/2-wire RS-485 data and D-Bus operation (EasyC-s)
- 5: NV: This LED can show:
  - Red: No video on in- or output;
  - Off: Video signal present.
- 6: 6-Pin data connector
- 7: 4-Pin connector for potential-free alarm contacts (channel CC1 and channel CC2).

### 3. Configuration and installation

**! Note on powering of a UTF TX-MSA with 24 Vac from the camera !**

The miniature stand-alone transmitter can convert 24 Vac power through an internal full rectifier bridge; the "-" of its internal DC voltage is connected to the metal housing. If the camera uses the same Vac power supply in parallel, but with a single-sided rectifier circuit, the UTF power supply diodes may suffer, since there always will be a connection between the housings through the coax cable shielding. To prevent the occurrence of such problems, proper measures must be taken to separate the two loads of the 24 Vac supply; this might be preferable in any case, as a precaution.

**If in doubt, please contact your distributor.**

#### Mounting

Before mounting the miniature transmitter, the mounting bracket has to be installed in a suitable place. After securing the bracket, the transmitter can be clicked into it. Make sure the transmitter is positioned and fixed correctly.

A stand-alone receiver can be installed nearly everywhere. When more than one receiver is needed, use Siquira MC 10 and MC 11 cabinets.

#### RS-485/422 connection

Before connecting the system, the RS-485 connection needs to be configured for 2-wire or 4-wire mode. This can be done with the upper switch (2W - 4W, see figure 4 pos. 4) on the front panel of the receiver. The positions are indicated on the front panel.

The connections between the transmitter ↔ camera, and receiver ↔ controller in 4-wire and in 2-wire mode are indicated in figures 5 and 6, respectively.

#### 4-wire mode:

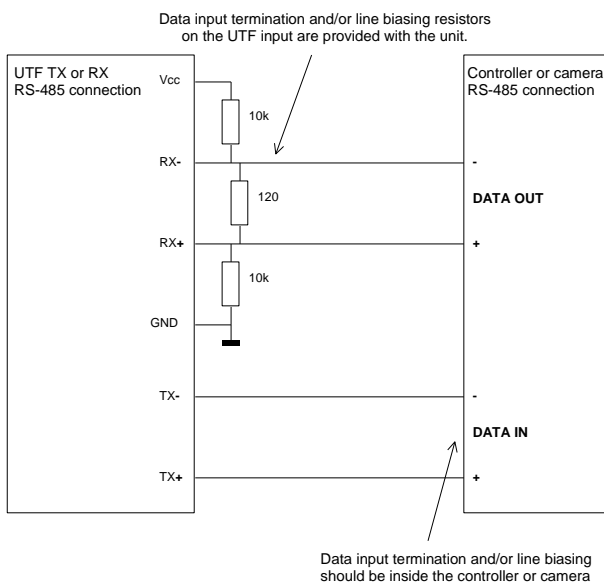

Figure 5. 4-Wire connection

#### 2-wire mode:

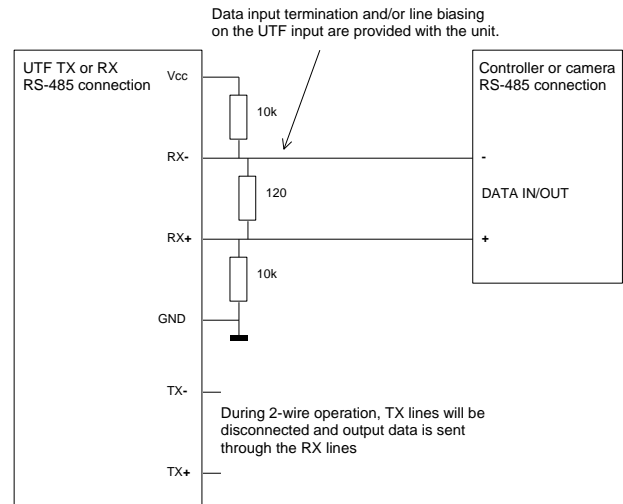

Figure 6.  
2-Wire connection

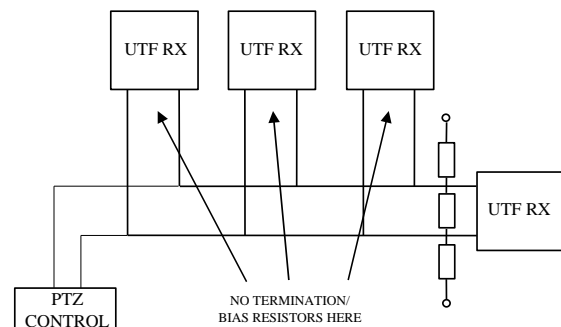

Figure 7.  
Termination and bias example, front panel bus configuration

#### Termination and bias resistors

When connecting more than one UTF in a bus structure, only one data input on the UTF modules needs to be terminated and/or biased. The resistors can be attached to the external connectors. Whether they are needed depends on the termination and bias resistors in the camera, etc.

#### EasyC-s™

With the lower switch (D-bus, see figure 4 pos. 4) in the "ON" position, the external data going into the data input (see figure 4 pos. 6) is put onto the internal data bus, while a UTF receiver is then also enabled to such get data from this internal data bus. To minimise external wiring, the UTF models are fitted with EasyC-s™.

To be able to control a group of receivers with one external data connection, the lower switch has to be in the "ON" position for each receiver belonging to that group and the external data has to be connected to only one receiver of that group.

The single RS-485/422 data link in the lowest UTF RX needs no termination resistors.

#### Powering up a system

When powering up a system, the "SYNC" indicator on the transmitter should show green and the "SYNC" indicator on the receiver should also light up green. When no video signal is present, the "NV" indicators show red.

## 4. Care and maintenance

The modules are designed to be maintenance free. To guarantee reliable operation of the unit, take the following precautions:

- prevent dust from collecting on or in the equipment;
- protect the equipment against moisture;
- maintain cooling space around the equipment.

## 5. Technical specifications

For technical specifications, please refer to the data sheet of the relevant model.

## 6. Safety, EMC, ESD

### General

The safety information contained in this section, and on other pages of this manual, must be observed whenever this unit is operated, serviced, or repaired. Failure to comply with any precaution, warning, or instruction noted in the manual is in violation of the standards of design, manufacture, and intended use of the unit.

Installation, adjustment, maintenance and repair of this equipment are to be performed by trained personnel aware of the hazards involved. For correct and safe use of the equipment and in order to keep the equipment in a safe condition, it is essential that both operating and servicing personnel follow standard safety procedures in addition to the safety precautions and warnings specified in this manual, and that this unit be installed in locations accessible to trained service personnel only.

Siquira assumes no liability for the customer's failure to comply with any of these safety requirements.

### UL/IEC/EN 60950-1: General safety requirements

**The equipment described in this manual has been designed and tested according to the UL/IEC/EN 60950-1 safety requirements.**

*If there is any doubt regarding the safety of the equipment, do not put it into operation.* This might be the case when the equipment shows physical damage or is stressed beyond tolerable limits (e.g. during storage and transportation).

*Before opening the equipment, disconnect it from all power sources.* The equipment must be powered by a SELV<sup>\*)</sup> power supply.

When this unit is operated in extremely elevated temperature conditions, it is possible for internal and external metal surfaces to become extremely hot.

### Optical safety

**This optical equipment contains Class 1M lasers or LEDs and has been designed and tested to meet IEC 60825-1:1993+A1+A2 and IEC 60825-2:2004 safety class 1M requirements.**

*Optical equipment presents potential hazards to testing and servicing personnel owing to high levels of optical radiation.* When using magnifying optical instruments, avoid looking directly into the output of an operating transmitter or into the end of a fiber connected to an operating transmitter, or there will be a risk of permanent eye damage. Precautions should be taken to prevent exposure to optical radiation when the unit is removed from its enclosure or when the fiber is disconnected from the unit. The optical radiation is invisible to the eye.

*Use of controls or adjustments or procedures other than those specified herein may result in hazardous radiation exposure.*

The installer is responsible for ensuring that the label depicted below (background: yellow; border and text: black) is present in the restricted locations where this equipment is installed.



The locations of all optical connections are listed in the Indications and Connectors section of this manual.

Optical outputs and wavelengths are listed in the Technical Specifications section of this manual.

### EMC

**Warning:** Operation of this equipment in a residential environment could cause radio interference.

**This device has been tested and found to meet the CE regulations relating to EMC and complies with the limits for a Class A device, pursuant to Part 15 of the FCC rules.** Operation is subject to the following two conditions: (1) This device may not cause harmful interference, and (2) This device must accept any interference received, including interference that may cause undesired operation. These limits are designed to provide reasonable protection against interference to radio communications in any installation. The equipment generates, uses, and can radiate radio frequency energy; improper use or special circumstances may cause interference to other equipment or a performance decrease due to interference radiated by other equipment. In such cases, the user will have to take appropriate measures to reduce such interactions between this and other equipment.

Note that the warning above does not apply to TKH Security products which comply with the limits for a Class B device. For product-specific details, refer to the EU Declaration of Conformity.

*Any interruption of the shielding inside or outside the equipment could make the equipment more prone to fail EMC requirements.*

To ensure EMC compliance of the equipment, use shielded cables for all signal cables including Ethernet, such as CAT5E SF/UTP or better, as defined in ISO IEC 11801. For power cables, unshielded three wire cable (2p + PE) is acceptable. Ensure that all electrically connected components are carefully earthed and protected against surges (high voltage transients caused by switching or lightning).

### ESD

**Electrostatic discharge (ESD) can damage or destroy electronic components. Proper precautions should be taken against ESD when opening the equipment.**

<sup>\*)</sup> SELV: conforming to IEC 60950-1, <60 Vdc output, output voltage galvanically isolated from mains. All power supplies or power supply cabinets available from Siquira comply with these SELV requirements.

## 7. Product disposal



### Recycling

The unit contains valuable materials which qualify for recycling. In the interest of protecting the natural environment, properly recycling the unit at the end of its service life is imperative.

## 8. EU Declaration of Conformity

The EU Declaration of Conformity for this product is available at <http://www.tkhsecurity.com/support-files>.