

## Product Features

- Electrical interface specifications per SFF-8431
- Management interface specifications per SFF-8431 and SFF-8472
- SFP+ MSA package with duplex LC connector
- Uncooled 1310nm FP Laser
- Up to 10.3Gb/s bi-directional data links
- Single +3.3V power supply
- Class 1 laser safety certified
- Operating temperature Options
  - (Commercial) -5°C to +70°C
  - (Industrial) -40°C to +85°C
- Up to 220m on OM1, OM2, OM3 MMF
- RoHS Compliant



## Applications

- 10G Ethernet 220m data connections on MMF

## Descriptions

LX4013C(I)DR SFP+ transceivers, according to Enhanced 8.5 and 10 Gigabit Small Form Factor Pluggable “SFP+” Multi-Sourcing Agreement (MSA) SFF-8431 and SFF-8472, revision 10.4, are designed for serial optical data communications up to 220m over multimode fiber at a wavelength of 1310nm. They are compliant with 10GBASE-LRM.

LX4013C(I)DR offer commercial and industrial operating temperature options.

## Ordering Information

Table 1. Ordering Information

Part Number	Transmitter	Output Power	Receiver	Sensitivity	Reach	Temp	DDM	RoHS
LX4013CDR	1310nm FP	-6.5~ +0.5dBm	PIN	< -8.5dBm	220m	-5 ~ 70 °C	Available	Compliant
LX4013IDR	1310nm FP	-6.5~ +0.5dBm	PIN	< -8.5dBm	220m	-40 ~ 85 °C	Available	Compliant

## Pin Description

Table 2. Pin Description

Pin	Name	Function/Description	Notes
1	VeeT	Transmitter Ground	1

2	TX_Fault	Transmitter Fault (LVTTTL-O) - High indicates a fault condition	2
3	TX_Disable	Transmitter Disable (LVTTTL-I) – High or open disables the transmitter	3
4	SDA	Two wire serial interface Data Line (LVCMOS-I/O) (MOD-DEF2)	4
5	SCL	Two wire serial interface Clock Line (LVCMOS-I/O) (MOD-DEF1)	4
6	MOD_ABS	Module Absent (Output), connected to VeeT or VeeR in the module	5
7	RS0	Rate Select 0 – Not used, Presents high input impedance	-
8	RX_LOS	Receiver Loss of Signal (LVTTTL-O)	2
9	RS1	Rate Select 1 – Not used, Presents high input impedance	-
10	VeeR	Receiver Ground	1
11	VeeR	Receiver Ground	1
12	RD-	Inverse Received Data out (CML-O)	-
13	RD+	Received Data out (CML-O)	-
14	VeeR	Receiver Ground	-
15	VccR	Receiver Power - +3.3V	-
16	VccT	Transmitter Power - +3.3 V	-
17	VeeT	Transmitter Ground	1
18	TD+	Transmitter Data In (CML-I)	-
19	TD-	Inverse Transmitter Data In (CML-I)	-
20	VeeT	Transmitter Ground	1

**Notes:**

1. The module signal grounds are isolated from the module case.
2. This is an open collector/drain output that on the host board requires a 4.7KΩ to 10KΩ pull-up resistor to VccHost.
3. This input is internally biased high with a 4.7KΩ to 10KΩ pull-up resistor to VccT.
4. Two-Wire Serial interface clock and data lines require an external pull-up resistor dependent on the capacitance load.
5. This is a ground return that on the host board requires a 4.7KΩ to 10KΩ pull-up resistor to VccHost.

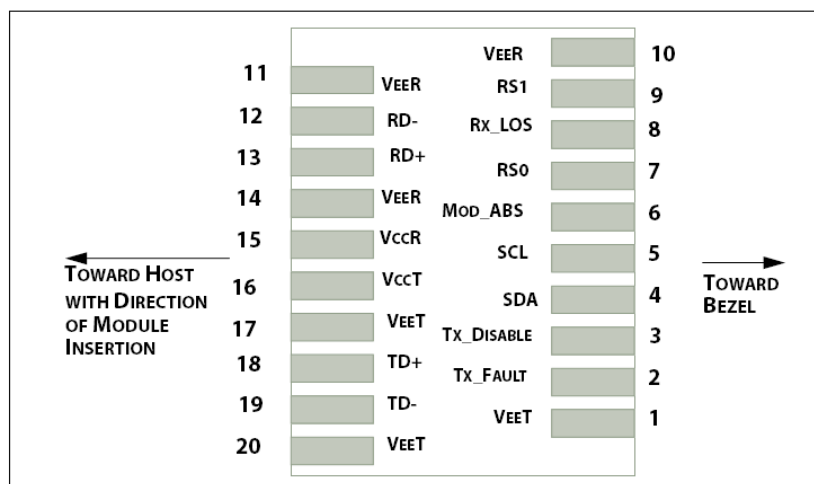

Figure 1. Host PCB SFP+ pad assignment top view

## Absolute Maximum Ratings

Stresses in excess of the absolute maximum ratings can cause permanent damage to the device. These are absolute stress ratings only. Functional operation of the device is not implied at these or

any other conditions in excess of those given in the operational sections of the data sheet. Exposure to absolute maximum ratings for extended periods can adversely affect device reliability.

**Table 3. Absolute Maximum Ratings**

Parameter	Symbol	Minimum	Maximum	Unit
Storage Temperature	T <sub>S</sub>	-40	85	°C
Relative Humidity	RH	5	95	%
Supply Voltage	V <sub>CC</sub>	-0.5	4.0	V

## Recommended Operating Conditions

**Table 4. Recommended Operating Conditions**

Parameter	Symbol	Min	Typ	Max	Unit
Operating Case Temperature	T <sub>C</sub>	-5	25	70	°C
Supply Voltage	V <sub>CC</sub>	3.135	3.3	3.465	V
Data Rate	-	-	10.3125	-	Gb/s

## Transceiver Electrical Characteristics

**Table 5. Transceiver Electrical Characteristics**

Parameter	Symbol	Minimum	Typical	Maximum	Unit	Notes	
Module Supply Current	I <sub>CC</sub>	-	-	290	mA	-	
Power Dissipation	P <sub>D</sub>	-	-	1000	mW	-	
<b>Transmitter</b>							
Input Differential Impedance	Z <sub>IN</sub>	-	100	-	Ω	-	
Differential Data Input Swing	V <sub>IN,P-P</sub>	180	-	700	mV <sub>P-P</sub>	-	
TX_FAULT	Transmitter Fault	V <sub>OH</sub>	2.0	-	V <sub>CCHOST</sub>	V	-
	Normal Operation	V <sub>OL</sub>	0	-	0.8	V	-
TX_DISABLE	Transmitter Disable	V <sub>IH</sub>	2.0	-	V <sub>CCHOST</sub>	V	-
	Transmitter Enable	V <sub>IL</sub>	0	-	0.8	V	-
<b>Receiver</b>							
Output Differential Impedance	Z <sub>O</sub>	-	100	-	Ω	-	
Differential Data Output Swing	V <sub>OUT,P-P</sub>	300	-	850	mV <sub>P-P</sub>	1	
Data Output Rise Time, Fall Time	t <sub>r</sub> , t <sub>f</sub>	28	-	-	ps	2	
RX_LOS	Loss of signal (LOS)	V <sub>OH</sub>	2.0	-	V <sub>CCHOST</sub>	V	3
	Normal Operation	V <sub>OL</sub>	0	-	0.8	V	3

**Notes:**

- Internally AC coupled, but requires a external 100Ω differential load termination.
- 20 – 80 %.
- LOS is an open collector output. Should be pulled up with 4.7kΩ on the host board.

## Transmitter Optical Characteristics

**Table 6. Transmitter Optical Characteristics**

Parameter	Symbol	Minimum	Typical	Maximum	Unit	Notes
Launch Optical Power	P <sub>o</sub>	-6.5	-	+0.5	dBm	1
Center Wavelength Range	λ <sub>c</sub>	1260	1310	1355	nm	-
Extinction Ratio	EX	3.5	-	-	dB	2
Optical Modulation Amplitude	OMA	-4.5	-	-	dBm	
Spectral Wavelength (RMS)	Δλ	-	-	3	nm	-
P <sub>out</sub> @TX-Disable Asserted	P <sub>off</sub>	-	-	-30	dBm	1
Eye Diagram	IEEE Std 802.3-2005 10Gb Ethernet 10GBASE-LR compatible					

**Notes:**

1. The optical power is launched into OM3 MMF.
2. Measured with a PRBS 2<sup>7</sup>-1 test pattern @10.3125Gbps.

## Receiver Optical Characteristics

**Table 7. Receiver Optical Characteristics**

Parameter	Symbol	Minimum	Typical	Maximum	Unit	Notes
Center Wavelength	λ <sub>c</sub>	1260	1310	1355	nm	-
Receiver Sensitivity (P <sub>avg</sub> )	S	-	-	-8.5	dBm	1
Receiver Sensitivity (OMA)	S <sub>OMA</sub>	-	-	-6.5	dBm	1
Receiver Overload (P <sub>avg</sub> )	P <sub>OL</sub>	0.5	-	-	dBm	1
Stressed Sensitivity (OMA)	-	-	-	-6.0	dBm	2
Optical Return Loss	ORL	12	-	-	dB	-
LOS De-Assert	LOS <sub>D</sub>	-	-	-11	dBm	-
LOS Assert	LOS <sub>A</sub>	-30	-	-	dBm	-
LOS Hysteresis	-	0.5	-	-	dB	-

**Notes:**

1. Measured with PRBS 2<sup>7</sup>-1 test pattern, 10.3125Gb/s, BER<10<sup>-12</sup>.
2. Comply with IEEE 802.3-2005.

## Recommended Host Board Power Supply Filter Network

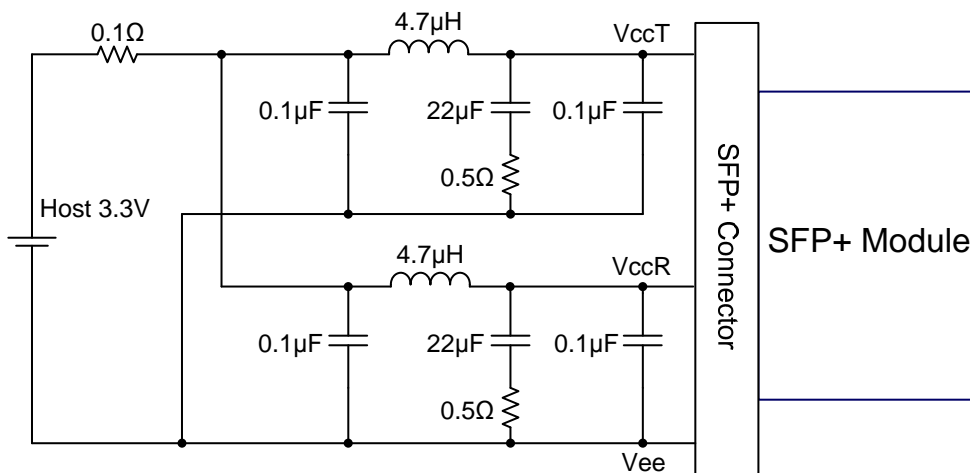

Figure 2. Recommended Host Board Power Supply Filter Network

## Recommended Application Interface Block Diagram

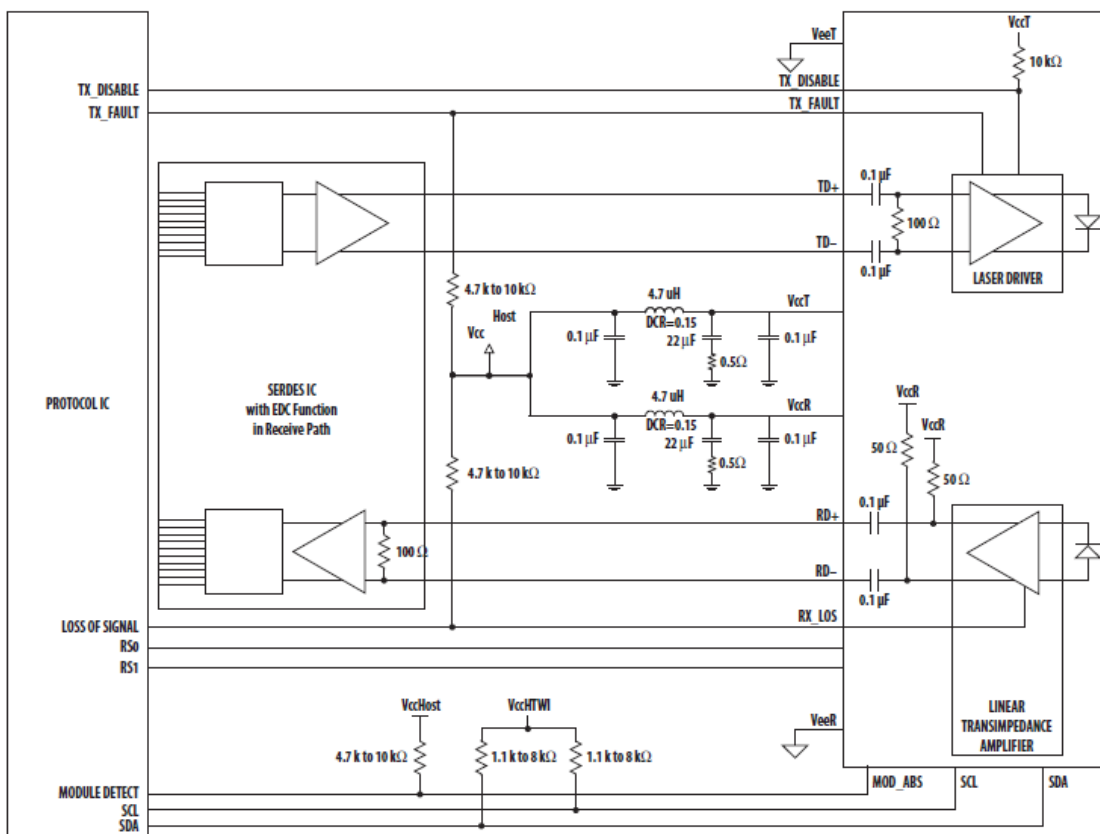

Figure 4. Recommended Application Interface Block Diagram

## Mechanical specifications

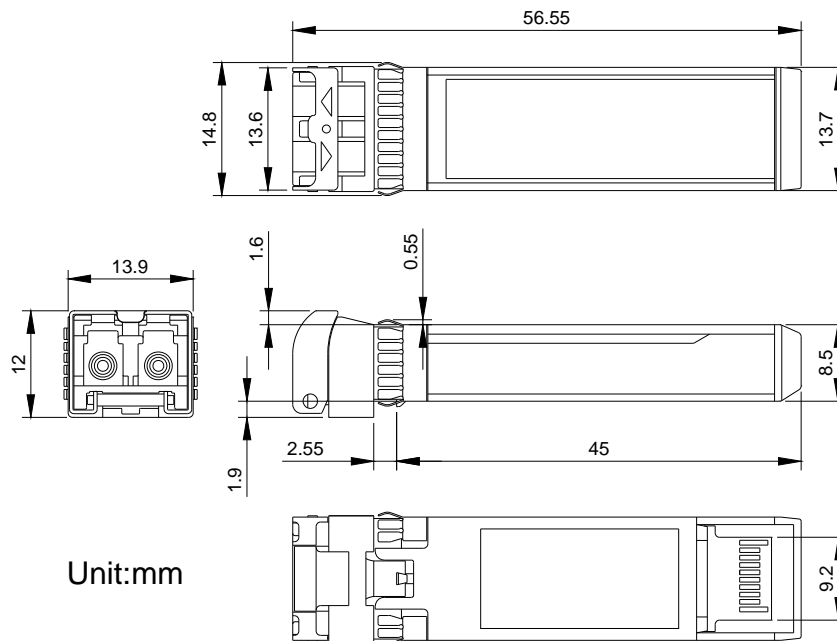
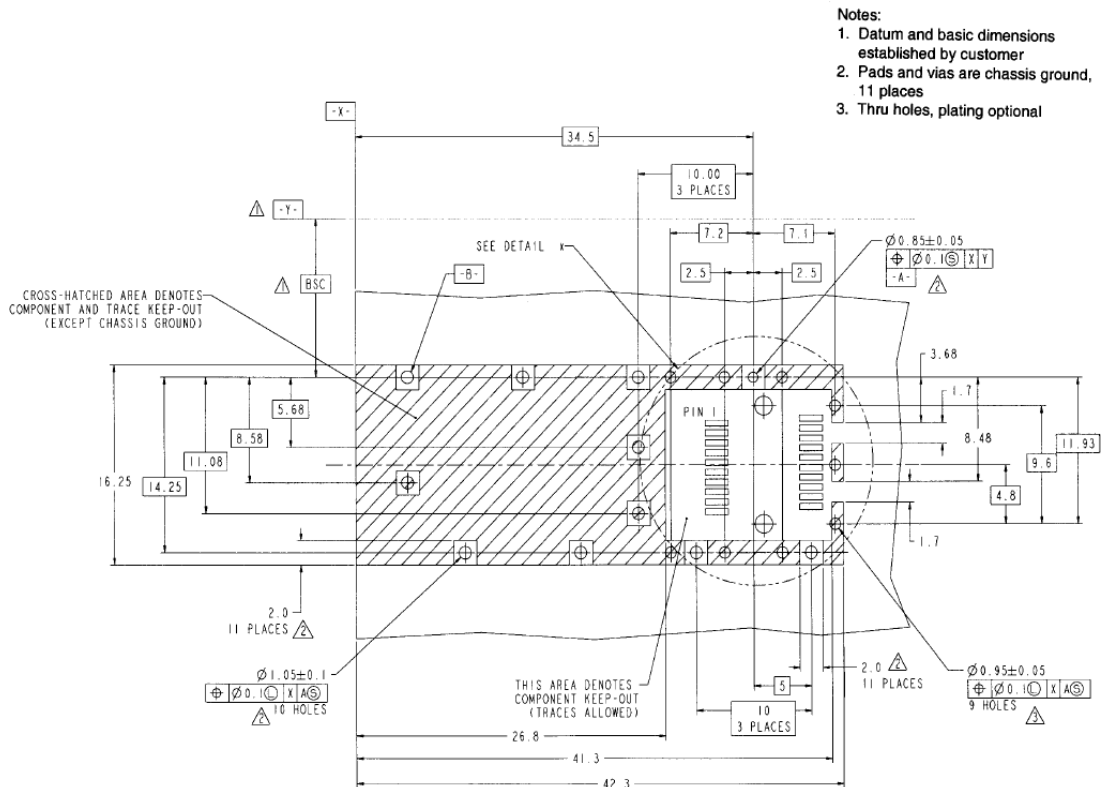

Figure 5. Outline Drawing

## PCB layout recommendation



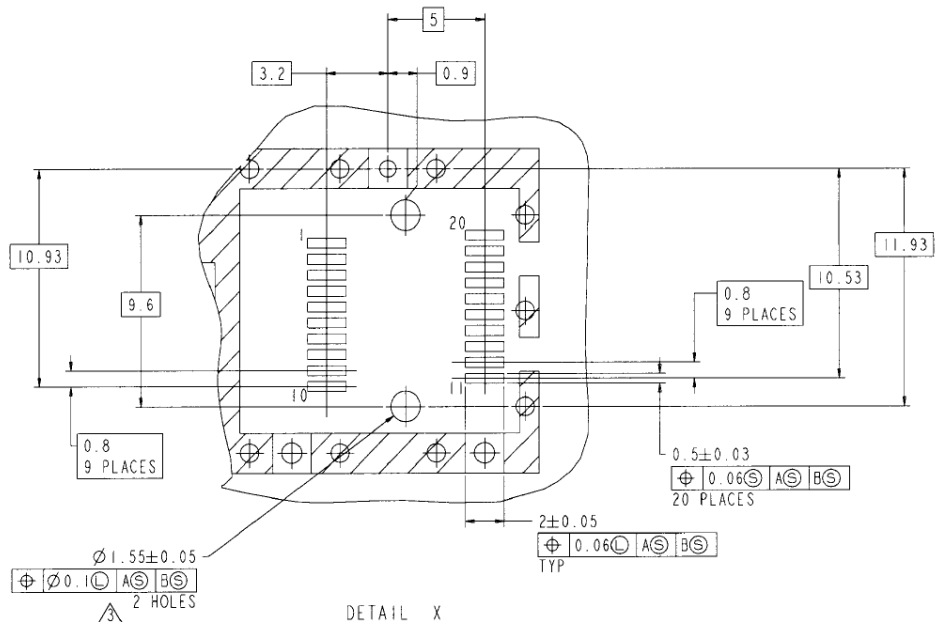

Figure 6. PCB layout recommendation

## For More Information

Linktel Technologies Co., Ltd

[sales@linkteltech.com](mailto:sales@linkteltech.com)

<http://www.linkteltech.com>

### Linktel China

No. 4, Bldg. B5, Hang Yu, Wuhan University Science Park

East Lake Hi-tech Development Zone, Wuhan, 430223, China

Tel: +86 27-87929302

### Linktel USA

3391 Ingersoll Ct., San Jose, CA 95148

Tel: +1-408-2613988