

Product Features

- ~ Compliant with ITU-T G.691 STM-64 I-64.1|
- ~ Compliant to IEEE Std 802.3-2005
10Gb Ethernet 10GBase-LR/LW
- ~ XFP MSA Rev. 4.5 compliant
- ~ Full digital diagnostic management interface
- ~ XFP MSA package with duplex LC connector
- ~ Uncooled 1310nm DFB Laser
- ~ Up to 11.3Gb/s bi-directional data links
- ~ Class 1 laser safety certified
- ~ Operating temperature options
 - (Commercial) 0 °C to +70 °C
 - (Industrial) - 40 °C to +85 °C
- ~ Up to 10km on 9/125µm SMF
- ~ RoHS Compliant



Applications

- ~ SDH STM-64 I-64.1
- ~ SONET OC-192 SR-1
- ~ 10G Ethernet 10GBASE-LR/LW
- ~ 10G Fiber Channel 1200-SM-LL-L

Descriptions

LX3002xDR XFP transceivers, according to 10 Gigabit Small Form Factor Pluggable Module Multi-Sourcing Agreement (XFP-MSA) INF-8077i Revision 4.5, are designed for serial optical data communications at 9.95 Gb/s to 11.3 Gb/s. They are compatible with SDH STM-64 I-64.1, IEEE Std 802.3-2005 10G Ethernet 10GBase-LR/LW and 10G Fiber Channel 1200-SM-LL-L.

LX3002xDR offer commercial and industrial operating temperature options.

Ordering Information

Table 1. Ordering Information

Part Number	Transmitter	Output Power	Receiver	Sensitivity	Reach	Temp	DDM	RoHS
LX3002CDR	1310nm DFB	-6 ~ -1dBm	PIN	< -14dBm	10km	0 ~ 70 °C	Available	Compliant
LX3002IDR	1310nm DFB	-6 ~ -1dBm	PIN	< -14dBm	10km	-40 ~ 85 °C	Available	Compliant

Electrical Pin Description

Table 2. Electrical Pin Description

Logic	Symbol	Name/Description	Note
-------	--------	------------------	------

1	-	GND	Module Ground	1
2	-	V _{EE5}	Optional -5.2V Power Supply - Not Required	-
3	LVTTL-I	Mod_DeSel	Module De-select; When held low allows module to respond to 2-wire serial interface	-
4	LVTTL-O	Interrupt	Interrupt; Indicates presence of an important condition which can be read over the 2-wire serial interface	2
5	LVTTL-I	TX_DIS	Transmitter Disable; Turns off transmitter laser output	-
6	-	V _{CC5}	+5V Power Supply- Not Required	-
7	-	GND	Module Ground	1
8	-	V _{CC3}	+3.3V Power Supply	-
9	-	V _{CC3}	+3.3V Power Supply	-
10	LVTTL-I/O	SCL	2-Wire Serial Interface Clock	2
11	LVTTL-I/O	SDA	2-Wire Serial Interface Data Line	2
12	LVTTL-O	Mod_Abs	Indicates Module is not present. Grounded in the Module	2
13	LVTTL-O	Mod_NR	Module Not Ready; Indicating Module Operational Fault	2
14	LVTTL-O	RX_LOS	Receiver Loss Of Signal Indicator	2
15	-	GND	Module Ground	1
16	-	GND	Module Ground	1
17	CML-O	RD-	Receiver Inverted Data Output	-
18	CML-O	RD+	Receiver Non-Inverted Data Output	-
19	-	GND	Module Ground	1
20	-	V _{CC2}	+1.8V Power Supply - Not Required	-
21	LVTTL-I	P_Down/RST	Power down; When high, requires the module to limit power consumption to 1.5W or below. 2-Wire serial interface must be functional in the low power mode. Reset; The falling edge initiates a complete reset of the module including the 2-wire serial interface, equivalent to a power cycle.	-
22	-	V _{CC2}	+1.8V Power Supply - Not Required	-
23	-	GND	Module Ground	1
24	PECL-I	RefCLK+	Reference Clock Non-Inverted Input, AC coupled on the host board - Not Required	3
25	PECL-I	RefCLK-	Reference Clock Inverted Input, AC coupled on the host board - Not Required	3
26	-	GND	Module Ground	1
27	-	GND	Module Ground	1
28	CML-I	TD-	Transmitter Inverted Data Input	-
29	CML-I	TD+	Transmitter Non-Inverted Data Input	-
30	-	GND	Module Ground	1

Notes:

1. Module ground pins GND are isolated from the module case.
2. Shall be pulled up with 4.7KΩ to 10KΩ to a voltage between 3.15V and 3.45V on the host board.
3. Reference Clock is not required. If present, it will be ignored.

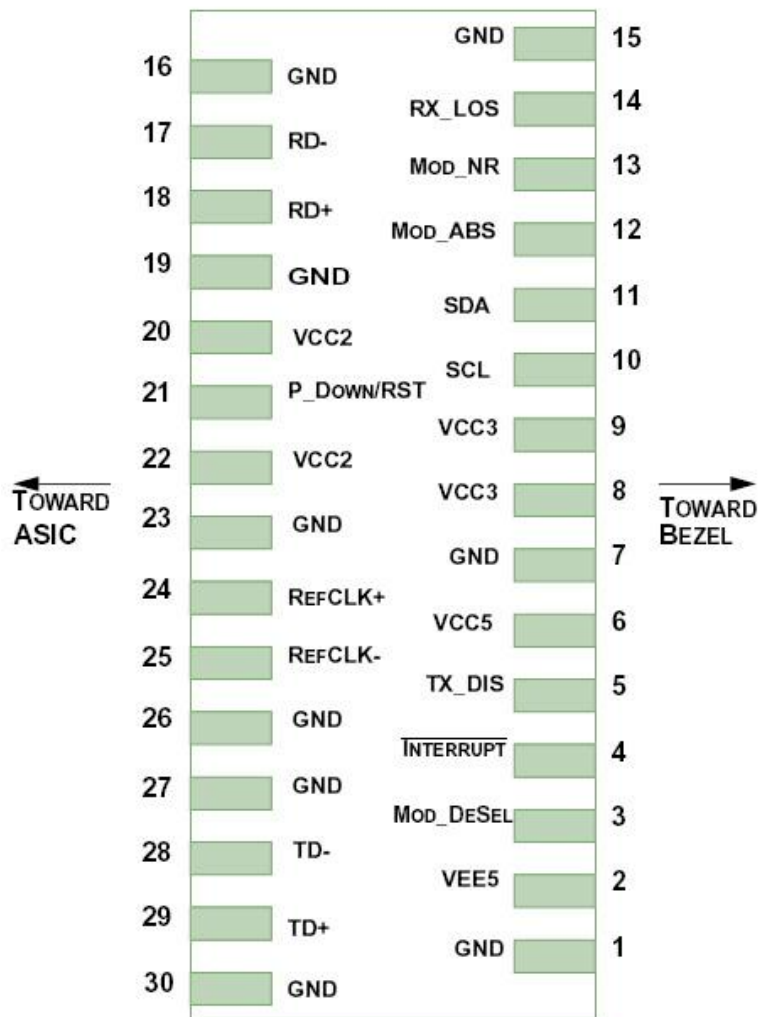

Figure 1. Host PCB XFP Pinout Top View

Absolute Maximum Ratings

Stresses in excess of the absolute maximum ratings can cause permanent damage to the device. These are absolute stress ratings only. Functional operation of the device is not implied at these or any other conditions in excess of those given in the operational sections of the data sheet. Exposure to absolute maximum ratings for extended periods can adversely affect device reliability.

Table 3. Absolute Maximum Ratings

Parameter	Symbol	Minimum	Maximum	Unit
Storage Temperature	T_S	-40	85	°C
Relative Humidity	RH	5	95	%
Supply Voltage	V_{CC3}	-0.5	4.0	V

Recommended Operating Conditions

Parameter	Symbol	Min	Typ	Max	Unit
Operating Case Temperature (Commercial)	T_C	0	25	70	°C
Operating Case Temperature (Industrial)	T_C	-40	25	85	°C
Supply Voltage	V_{CC3}	3.135	3.3	3.465	V
Data Rate	-	9.95	-	11.3	Gb/s

Table 4. Recommended Operating Conditions

Transceiver Electrical Characteristics

Table 5. Transceiver Electrical Characteristics

Parameter	Symbol	Minimum	Typical	Maximum	Unit	Notes
Supply Current	I_{CC3}	-	-	600	mA	-
Power Dissipation	P_D	-	1500	2000	mW	-
Transmitter						
Input Differential Impedance	Z_{IN}	-	100	-	Ω	-
Differential Data Input Swing	$V_{IN,P-P}$	120	-	1000	mV _{P-P}	-
Tx_Disable, P_Down/RST	V_{IH}	2.0	-	$V_{CC3}+0.3$	V	-
	V_{IL}	-0.3	-	0.8	V	-
Transmit Disable Assert Time	-	-	-	10	us	-
Receiver						
Output Differential Impedance	Z_O	-	100	-	Ω	-
Differential Data Output Swing	$V_{OUT,P-P}$	340	-	850	mV _{P-P}	1
Data Output Rise Time, Fall Time	t_r, t_f	24	-	-	ps	2
Rx_LOS, Mod_NR, Interrupt	V_{OH}	$V_{CCHOST}-0.5$	-	$V_{CCHOST}+0.3$	V	3
	V_{OL}	0	-	0.4	V	3

Notes:

- Internally AC coupled, but requires a external 100 Ω differential termination.
- 20 – 80 %.
- Loss Of Signal is an open collector output. Should be pulled up with a 4.7k Ω -10k Ω resistor on the host board.

Transmitter Optical Characteristics

Table 6. Transmitter Optical Characteristics

Parameter	Symbol	Minimum	Typical	Maximum	Unit	Notes
Launch Average Optical Power	P_o	-6	-	-1	dBm	1
Center Wavelength Range	λ_c	1290	-	1330	nm	-

Extinction Ratio	EX	6	-	-	dB	2
Spectral Width (-20dB)	$\Delta\lambda$	-	-	1	nm	-
Side Mode Suppression Ratio	SMSR	30	-	-	dB	-
Transmitter and Dispersion Penalty	TDP	-	-	1	dB	3
Average Optical Power (Laser Off)	P_{OFF}	-	-	-30	dBm	1
Eye Diagram	ITU-T G.691 SDH STM-64 I-64.1 compatible					2

Notes:

1. The optical power is launched into 9/125 μ m SMF.
2. Measured with a PRBS 2³¹-1 test pattern @ 9.953Gbps.
3. Measured with 10km G.652 SMF.

Receiver Optical Characteristics

Table 7. Receiver Optical Characteristics

Parameter	Symbol	Minimum	Typical	Maximum	Unit	Notes
Center Wavelength	λ_c	1270	-	1600	nm	-
Receiver Sensitivity (P_{avg})	S	-	-	-14	dBm	1
Receiver Overload (P_{avg})	P_{OL}	0.5	-	-	dBm	1
Optical Return Loss	ORL	14	-	-	dB	-
LOS De-Assert	LOS_D	-	-	-15	dBm	-
LOS Assert	LOS_A	-25	-	-	dBm	-
LOS Hysteresis	-	0.5	-	-	dB	-

Notes:

1. Measured with worst ER; 1310nm; PRBS 2³¹-1 test pattern, BER<10⁻¹².

Recommended Host Board Power Supply Filter Network

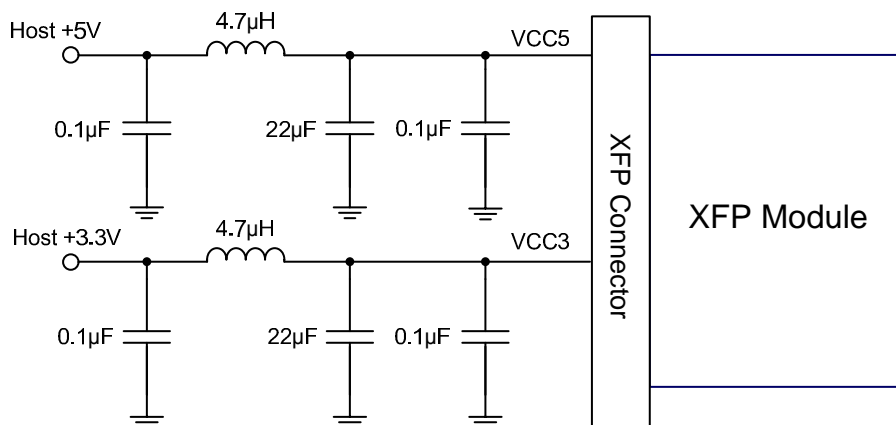

Figure 2. Recommended Host Board Power Supply Filter Network

Recommended Application Interface Block Diagram

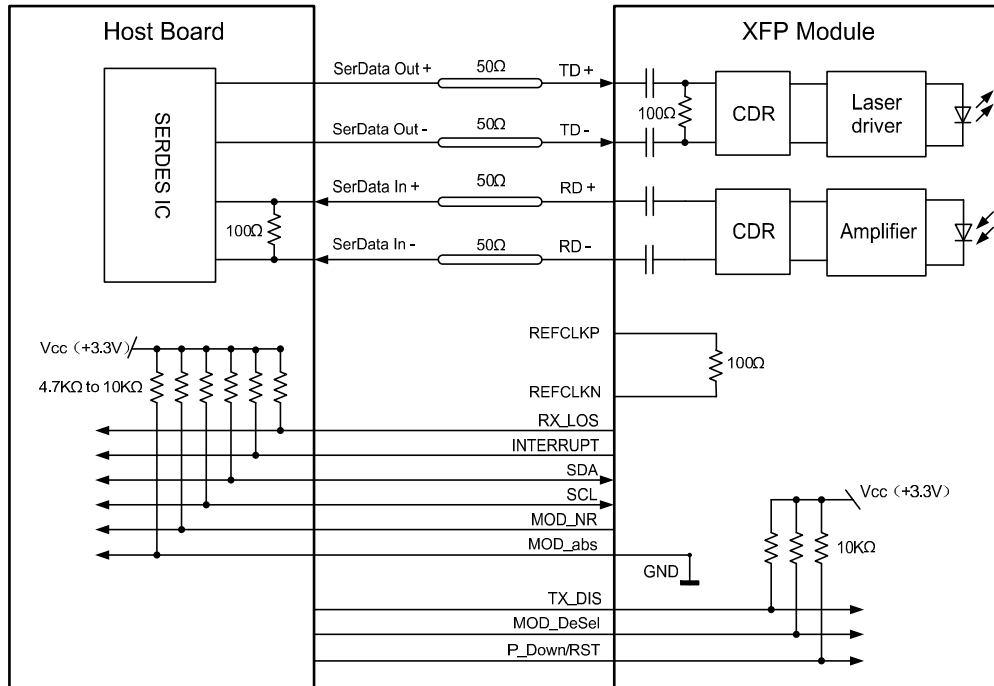

Figure 3. Recommended Application Interface Block Diagram

Mechanical specifications

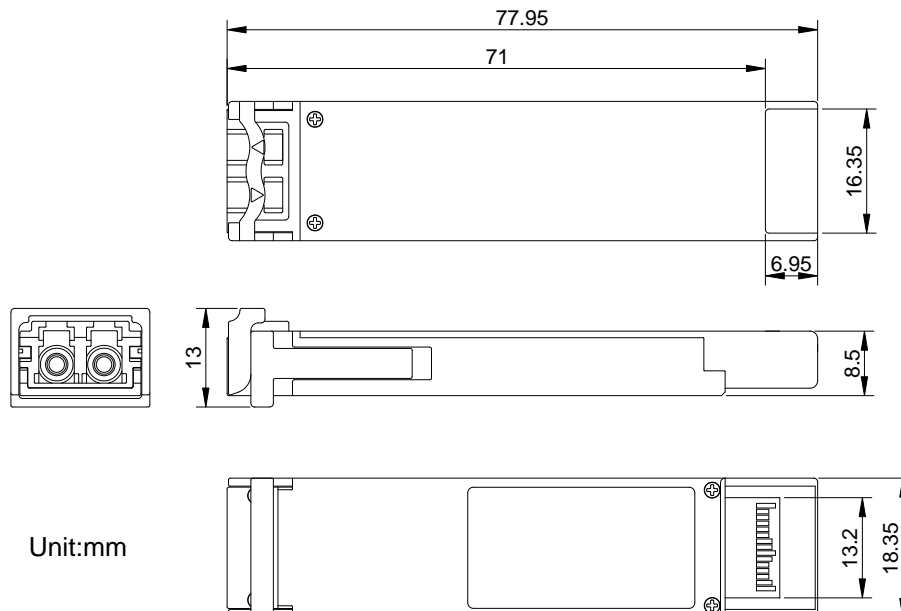

Figure 4. Outline Drawing

For More Information

Linktel Technologies Co., Ltd

sales@linkteltech.com

<http://www.linkteltech.com>

Linktel China

No. 4, Bldg. B5, Hang Yu, Wuhan University Science Park
East Lake Hi-tech Development Zone, Wuhan, 430223, China
Tel: +86 27-87929302

Linktel USA

3391 Ingersoll Ct., San Jose, CA 95148
Tel: +1-408-2613988