

Product Features

- Compliant with IEEE Std 802.3-2005 10Gb Ethernet 10GBase-SR/SW
- XFP MSA Rev. 4.5 compliant
- Full digital diagnostic management interface
- XFP MSA package with duplex LC connector
- Uncooled 850nm VCSEL Laser
- Up to 11.3Gb/s bi-directional data links
- Class 1 laser safety certified
- Operating temperature Options
 - (Commercial) 0°C to +70°C
 - (Industrial) -40°C to +85°C
- Up to 300m on 2000 MHz km MMF
- RoHS Compliant



Applications

- 10G Ethernet 10GBASE-SR/SW
- 10G Fiber Channel 1200-Mx-SN-I

Descriptions

LX3001C(I)DR XFP transceivers, according to 10 Gigabit Small Form Factor Pluggable Module Multi-Sourcing Agreement (XFP-MSA) INF-8077i Revision 4.5, are designed for serial optical data communications up to 300m on multimode fiber. They are compliant with IEEE Std 802.3-2005 10G Ethernet 10GBase-SR /SW and 10G Fiber Channel 1200-Mx-SN-I.

LX3001C(I)DR offer commercial and industrial operating temperature options.

Ordering Information

Table 1. Ordering Information

Part Number	Transmitter	Output Power	Receiver	Sensitivity	Reach	Temp	DDM	RoHS
LX3001CDR	850nm VCSEL	-7.3 ~ -1dBm	PIN	< -11.1dBm	300m	0 ~ 70 °C	Available	Compliant
LX3001IDR	850nm VCSEL	-7.3 ~ -1dBm	PIN	< -11.1dBm	300m	-40 ~ 85 °C	Available	Compliant

Electrical Pin Description

Table 2. Electrical Pin Description

Pin	Logic	Symbol	Name/Description	Note
1	-	GND	Module Ground	1

2	-	V _{EE5}	Optional -5.2V Power Supply - Not Required	-
3	LVTTTL-I	Mod_DeSel	Module De-select; When held low allows module to respond to 2-wire serial interface	-
4	LVTTTL-O	Interrupt	Interrupt; Indicates presence of an important condition which can be read over the 2-wire serial interface	2
5	LVTTTL-I	TX_DIS	Transmitter Disable; Turns off transmitter laser output	-
6	-	V _{CC5}	+5V Power Supply	-
7	-	GND	Module Ground	1
8	-	V _{CC3}	+3.3V Power Supply	-
9	-	V _{CC3}	+3.3V Power Supply	-
10	LVTTTL-I/O	SCL	2-Wire Serial Interface Clock	2
11	LVTTTL-I/O	SDA	2-Wire Serial Interface Data Line	2
12	LVTTTL-O	Mod_Abs	Indicates Module is not present. Grounded in the Module	2
13	LVTTTL-O	Mod_NR	Module Not Ready; Indicating Module Operational Fault	2
14	LVTTTL-O	RX_LOS	Receiver Loss Of Signal Indicator	2
15	-	GND	Module Ground	1
16	-	GND	Module Ground	1
17	CML-O	RD-	Receiver Inverted Data Output	-
18	CML-O	RD+	Receiver Non-Inverted Data Output	-
19	-	GND	Module Ground	1
20	-	V _{CC2}	+1.8V Power Supply - Not Required	-
21	LVTTTL-I	P_Down/RST	Power down; When high, requires the module to limit power consumption to 1.5W or below. 2-Wire serial interface must be functional in the low power mode. Reset; The falling edge initiates a complete reset of the module including the 2-wire serial interface, equivalent to a power cycle.	-
22	-	V _{CC2}	+1.8V Power Supply - Not Required	-
23	-	GND	Module Ground	1
24	PECL-I	RefCLK+	Reference Clock Non-Inverted Input, AC coupled on the host board - Not Required	3
25	PECL-I	RefCLK-	Reference Clock Inverted Input, AC coupled on the host board - Not Required	3
26	-	GND	Module Ground	1
27	-	GND	Module Ground	1
28	CML-I	TD-	Transmitter Inverted Data Input	-
29	CML-I	TD+	Transmitter Non-Inverted Data Input	-
30	-	GND	Module Ground	1

Notes:

1. Module ground pins GND are isolated from the module case.
2. Shall be pulled up with 4.7KΩ to 10KΩ to a voltage between 3.15V and 3.45V on the host board.
3. Reference Clock is not required. If present, it will be ignored.

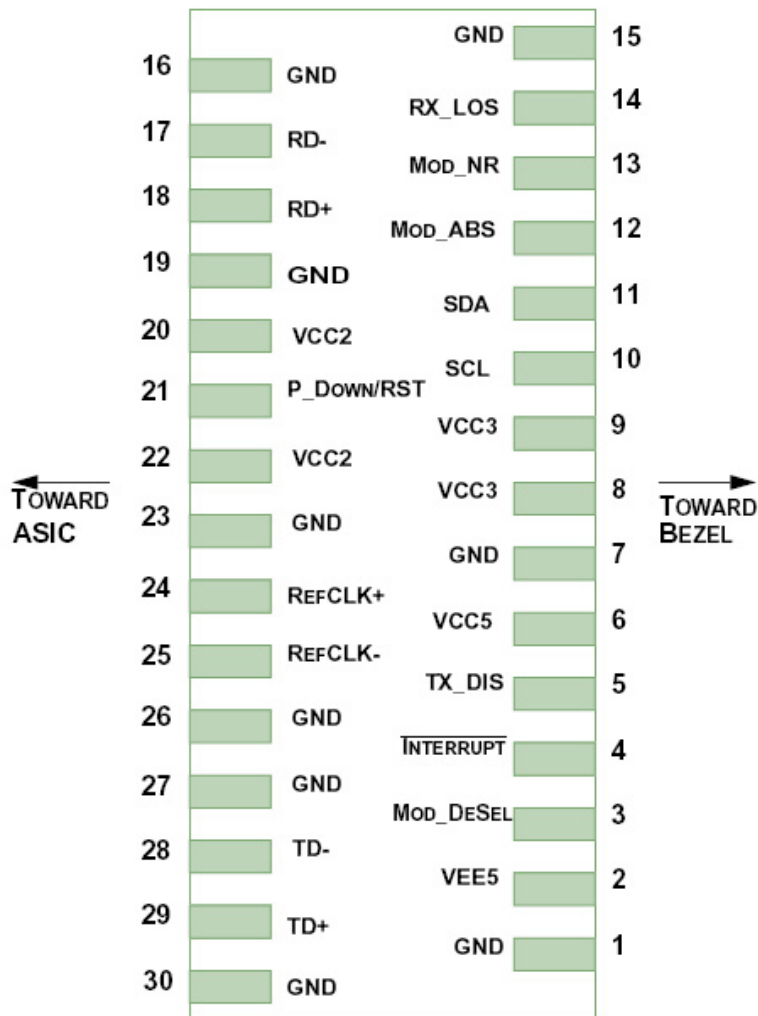

Figure 1. Host PCB XFP Pinout Top View

Absolute Maximum Ratings

Stresses in excess of the absolute maximum ratings can cause permanent damage to the device. These are absolute stress ratings only. Functional operation of the device is not implied at these or any other conditions in excess of those given in the operational sections of the data sheet. Exposure to absolute maximum ratings for extended periods can adversely affect device reliability.

Table 3. Absolute Maximum Ratings

Parameter	Symbol	Minimum	Maximum	Unit
Storage Temperature	T_S	-40	85	°C
Relative Humidity	RH	5	95	%
Supply Voltage	V_{CC3}	-0.5	4.0	V
Supply Voltage	V_{CC5}	-0.5	6.0	V

Recommended Operating Conditions

Table 4. Recommended Operating Conditions

Parameter	Symbol	Min	Typ	Max	Unit
Operating Case Temperature (Commercial)	T_C	0	-	70	°C
Operating Case Temperature (Industrial)	T_C	-40	-	85	°C
Supply Voltage	V_{CC3}	3.135	3.3	3.465	V
Data Rate	-	9.95	-	11.3	Gb/s

Transceiver Electrical Characteristics

Table 5. Transceiver Electrical Characteristics

Parameter	Symbol	Minimum	Typical	Maximum	Unit	Notes
Supply Current	I_{CC3}	-	-	430	mA	-
Power Dissipation	P_D	-	-	1500	mW	-
Transmitter						
Input Differential Impedance	Z_{IN}	-	100	-	Ω	-
Differential Data Input Swing	$V_{IN,P-P}$	120	-	1000	mV _{P-P}	-
Tx_Disable, P_Down/RST	V_{IH}	2.0	-	$V_{CC3}+0.3$	V	-
	V_{IL}	-0.3	-	0.8	V	-
Transmit Disable Assert Time	-	-	-	10	us	-
Receiver						
Output Differential Impedance	Z_O	-	100	-	Ω	-
Differential Data Output Swing	$V_{OUT,P-P}$	400	-	800	mV _{P-P}	1
Data Output Rise Time, Fall Time	t_r, t_f	-	-	40	ps	2
Rx_LOS, Mod_NR, Interrupt	V_{OH}	$V_{CCHOST}-0.5$	-	$V_{CCHOST}+0.3$	V	3
	V_{OL}	0	-	0.4	V	3

Notes:

- Internally AC coupled, but requires a external 100 Ω differential termination.
- 20 – 80 %.
- Loss Of Signal is an open collector output. Should be pulled up with a 4.7k Ω -10k Ω resistor on the host board.

Transmitter Optical Characteristics

Table 6. Transmitter Optical Characteristics

Parameter	Symbol	Minimum	Typical	Maximum	Unit	Notes
Launch Average Optical Power	P_o	-7.3	-	-1	dBm	1
Center Wavelength Range	λ_c	840	850	860	nm	-
Extinction Ratio	EX	3	-	-	dB	2

Optical Modulation Amplitude	OMA	Refer to Table 7			dBm	1
Spectral Width (RMS)	$\Delta\lambda$	Refer to Table 7			nm	-
Transmitter and Dispersion Penalty	TDP	-	-	3.9	dB	-
Average Optical Power (Laser Off)	P _{OFF}	-	-	-30	dBm	1
Eye Diagram	ITU-T G.691 SDH STM-64 I-64.1 compatible					2

Notes:

1. 50/125 μ m fiber with NA = 0.2, 62.5/125 μ m fiber with NA = 0.275.
2. Measured with a PRBS 2³¹-1 test pattern @10.3125Gbps.

Table 7. Minimum Optical Modulation Amplitude as a function of center wavelength and spectral width

Center Wavelength (nm)	RMS Spectral Width (nm)								
	Up to 0.05	0.05 to 0.1	0.1 to 0.15	0.15 to 0.2	0.2 to 0.25	0.25 to 0.3	0.3 to 0.35	0.35 to 0.4	0.4 to 0.45
840 to 842	-4.2	-4.2	-4.1	-4.1	-3.9	-3.8	-3.5	-3.2	-2.8
842 to 844	-4.2	-4.2	-4.2	-4.1	-3.9	-3.8	-3.6	-3.3	-2.9
844 to 846	-4.2	-4.2	-4.2	-4.1	-4.0	-3.8	-3.6	-3.3	-2.9
846 to 848	-4.3	-4.2	-4.2	-4.1	-4.0	-3.8	-3.6	-3.3	-2.9
848 to 850	-4.3	-4.2	-4.2	-4.1	-4.0	-3.8	-3.6	-3.3	-3.0
850 to 852	-4.3	-4.2	-4.2	-4.1	-4.0	-3.8	-3.6	-3.4	-3.0
852 to 854	-4.3	-4.2	-4.2	-4.1	-4.0	-3.9	-3.7	-3.4	-3.1
854 to 856	-4.3	-4.3	-4.2	-4.1	-4.0	-3.9	-3.7	-3.4	-3.1
856 to 858	-4.3	-4.3	-4.2	-4.1	-4.0	-3.9	-3.7	-3.5	-3.1
858 to 860	-4.3	-4.3	-4.2	-4.2	-4.1	-3.9	-3.7	-3.5	-3.2

Receiver Optical Characteristics

Table 8. Receiver Optical Characteristics

Parameter	Symbol	Minimum	Typical	Maximum	Unit	Notes
Center Wavelength	λ_c	840	-	860	nm	-
Receiver Sensitivity (P _{avg})	S	-	-	-9.9	dBm	1
Receiver Sensitivity (OMA)	S _{OMA}	-	-	-11.1	dBm	1
Receiver Overload (P _{avg})	P _{OL}	-1.0	-	-	dBm	1
Stressed Sensitivity (OMA)	-	-	-	-7.5	dBm	2
Optical Return Loss	ORL	12	-	-	dB	-
LOS De-Assert	LOS _D	-	-	-12	dBm	-
LOS Assert	LOS _A	-30	-	-	dBm	-
LOS Hysteresis	-	0.5	-	-	dB	-

Notes:

1. Measured with worst ER; PRBS 2³¹-1 test pattern, BER<10⁻¹².
2. Comply with IEEE Std 802.3-2005.

Recommended Host Board Power Supply Filter Network

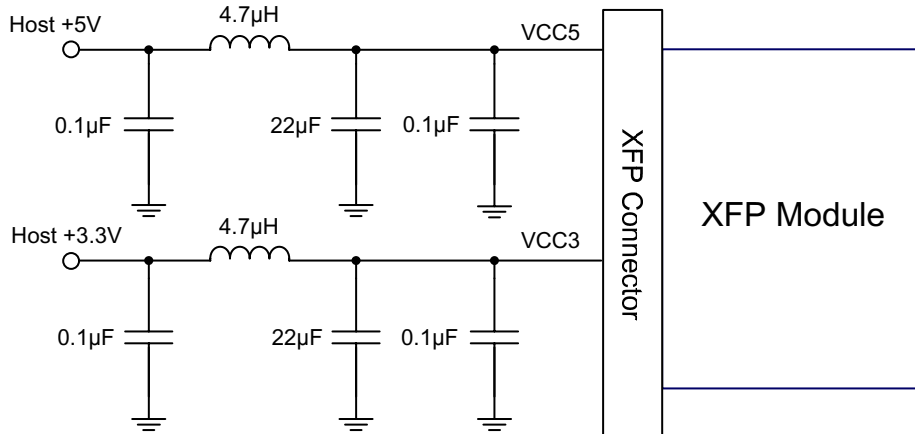

Figure 2. Recommended Host Board Power Supply Filter Network

Recommended Application Interface Block Diagram

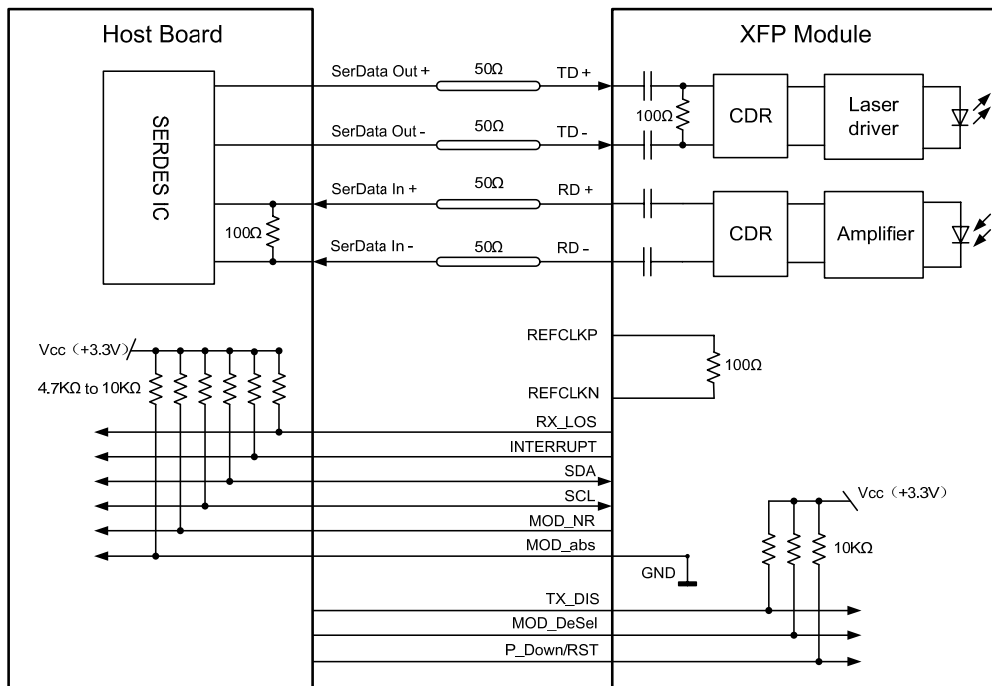

Figure 3. Recommended Application Interface Block Diagram

Mechanical specifications

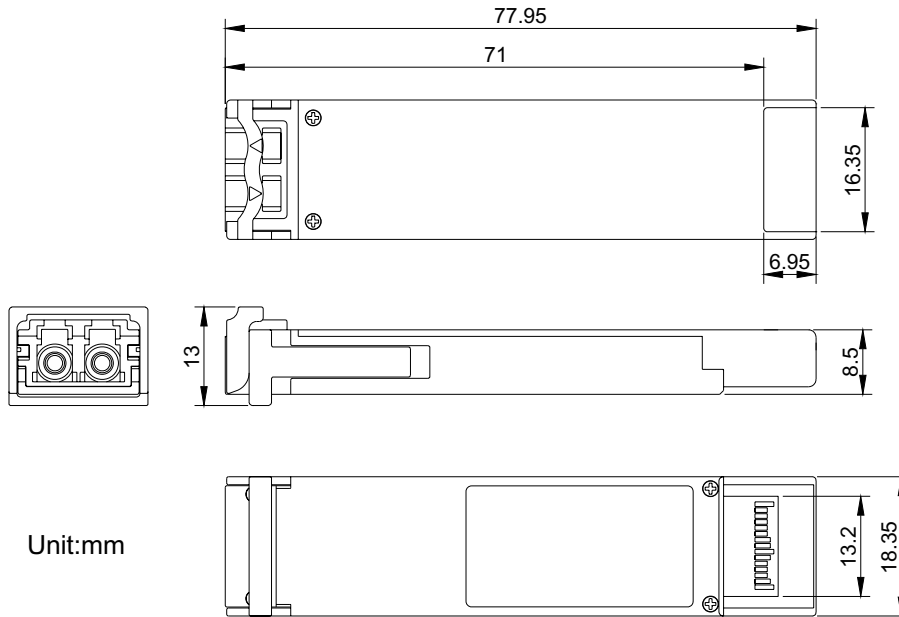

Figure 4. Outline Drawing



LX3001
10Gb/s 850nm XFP Optical Transceiver
10GBASE-SR / 10GBASE-SW

For More Information

Linktel Technologies Co., Ltd

sales@linkteltech.com

<http://www.linkteltech.com>

Linktel China

No. 4, Bldg. B5, Hang Yu, Wuhan University Science Park

East Lake Hi-tech Development Zone, Wuhan, 430223, China

Tel: +86 27-87929302

Linktel USA

3391 Ingersoll Ct., San Jose, CA 95148

Tel: +1-408-2613988