

Product Features

- Compliant with IEEE Std 802.3-2005
10G Ethernet 10GBase-ER/EW
- Electrical interface specifications per SFF-8431
- Management interface specifications per SFF-8431 and SFF-8472
- SFP+ MSA package with duplex LC connector
- Cooled EML Laser
- Up to 10.3Gb/s bi-directional data links
- Single +3.3V power supply
- Class 1 laser safety certified
- Commercial operating temperature:0°C to +70°C
- Up to 40km on 9/125µm SMF
- RoHS Compliant

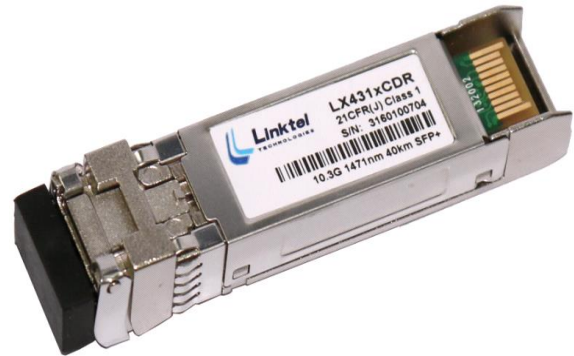

Applications

- 10G Ethernet 10GBASE-ER/EW
- 40km 10G CWDM Network

Descriptions

LX431xCDR SFP+ transceivers, according to Enhanced 8.5 and 10 Gigabit Small Form Factor Pluggable “SFP+” Multi-Sourcing Agreement (MSA) SFF-8431 and SFF-8472, revision 10.4, are designed for CWDM 10G ethernet data communications up to 40km over single mode fiber. They are compliant with IEEE Std 802.3-2005 10Gb Ethernet 10GBase-ER/EW.

LX431xCDR are compliant with RoHS.

Ordering Information

Table 1. Ordering Information

Part Number	Transmitter	Output Power	Receiver	Sensitivity	Reach	Temp	DDM	RoHS
LX4311CDR	1471nm EML	-1~ +3dBm	PIN	< -15.8dBm	40km	0 ~ 70 °C	Available	Compliant
LX4312CDR	1491nm EML	-1~ +3dBm	PIN	< -15.8dBm	40km	0 ~ 70 °C	Available	Compliant
LX4313CDR	1511nm EML	-1~ +3dBm	PIN	< -15.8dBm	40km	0 ~ 70 °C	Available	Compliant
LX4314CDR	1531nm EML	-1~ +3dBm	PIN	< -15.8dBm	40km	0 ~ 70 °C	Available	Compliant
LX4315CDR	1551nm EML	-1~ +3dBm	PIN	< -15.8dBm	40km	0 ~ 70 °C	Available	Compliant
LX4316CDR	1571nm EML	-1~ +3dBm	PIN	< -15.8dBm	40km	0 ~ 70 °C	Available	Compliant
LX4317CDR	1591nm EML	-1~ +3dBm	PIN	< -15.8dBm	40km	0 ~ 70 °C	Available	Compliant
LX4318CDR	1611nm EML	-1~ +3dBm	PIN	< -15.8dBm	40km	0 ~ 70 °C	Available	Compliant

Pin Description

Table 2. Pin Description

Pin	Name	Function/Description	Notes
1	VeeT	Transmitter Ground	1
2	TX_Fault	Transmitter Fault (LVTTTL-O) - High indicates a fault condition	2
3	TX_Disable	Transmitter Disable (LVTTTL-I) – High or open disables the transmitter	3
4	SDA	Two wire serial interface Data Line (LVCMOS-I/O) (MOD-DEF2)	4
5	SCL	Two wire serial interface Clock Line (LVCMOS-I/O) (MOD-DEF1)	4
6	MOD_ABS	Module Absent (Output), connected to VeeT or VeeR in the module	5
7	RS0	Rate Select 0 – Not used, Presents high input impedance	-
8	RX_LOS	Receiver Loss of Signal (LVTTTL-O)	2
9	RS1	Rate Select 1 – Not used, Presents high input impedance	-
10	VeeR	Receiver Ground	1
11	VeeR	Receiver Ground	1
12	RD-	Inverse Received Data out (CML-O)	-
13	RD+	Received Data out (CML-O)	-
14	VeeR	Receiver Ground	-
15	VccR	Receiver Power - +3.3V	-
16	VccT	Transmitter Power - +3.3 V	-
17	VeeT	Transmitter Ground	1
18	TD+	Transmitter Data In (CML-I)	-
19	TD-	Inverse Transmitter Data In (CML-I)	-
20	VeeT	Transmitter Ground	1

Notes:

1. The module signal grounds are isolated from the module case.
2. This is an open collector/drain output that on the host board requires a 4.7KΩ to 10KΩ pull-up resistor to VccHost.
3. This input is internally biased high with a 4.7KΩ to 10KΩ pull-up resistor to VccT.
4. Two-Wire Serial interface clock and data lines require an external pull-up resistor dependent on the capacitance load.
5. This is a ground return that on the host board requires a 4.7KΩ to 10KΩ pull-up resistor to VccHost.

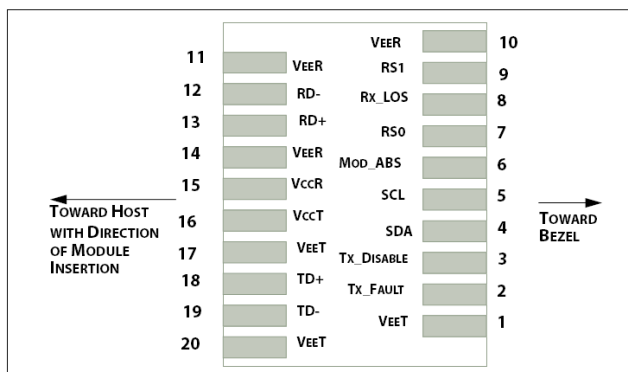

Figure 1. Host PCB SFP+ pad assignment top view

Absolute Maximum Ratings

Stresses in excess of the absolute maximum ratings can cause permanent damage to the device. These are absolute stress ratings only. Functional operation of the device is not implied at these or any other conditions in excess of those given in the operational sections of the data sheet. Exposure to absolute maximum ratings for extended periods can adversely affect device reliability.

Table 3. Absolute Maximum Ratings

Parameter	Symbol	Minimum	Maximum	Unit
Storage Temperature	T _s	-40	85	°C
Relative Humidity	RH	5	95	%
Supply Voltage	V _{CC}	-0.5	4.0	V

Recommended Operating Conditions

Table 4. Recommended Operating Conditions

Parameter	Symbol	Min	Typ	Max	Unit
Operating Case Temperature	T _c	0	25	70	°C
Supply Voltage	V _{CC}	3.135	3.3	3.465	V
Data Rate	-	-	10.3125	-	Gb/s

Transceiver Electrical Characteristics

Table 5. Transceiver Electrical Characteristics

Parameter	Symbol	Minimum	Typical	Maximum	Unit	Notes	
Module Supply Current	I _{CC}	-	-	450	mA	-	
Power Dissipation	P _D	-	-	1500	mW	-	
Transmitter							
Input Differential Impedance	Z _{IN}	-	100	-	Ω	-	
Differential Data Input Swing	V _{IN, P-P}	180	-	700	mV _{P-P}	-	
TX_FAULT	Transmitter Fault	V _{OH}	2.0	-	V _{CCHOST}	V	-
	Normal Operation	V _{OL}	0	-	0.8	V	-
TX_DISABLE	Transmitter Disable	V _{IH}	2.0	-	V _{CCHOST}	V	-
	Transmitter Enable	V _{IL}	0	-	0.8	V	-
Receiver							
Output Differential Impedance	Z _O	-	100	-	Ω	-	
Differential Data Output Swing	V _{OUT, P-P}	300	-	850	mV _{P-P}	1	
Data Output Rise Time, Fall Time	t _r , t _f	28	-	-	ps	2	

RX_LOS	Loss of signal (LOS)	V_{OH}	2.0	-	V_{CCHOST}	V	3
	Normal Operation	V_{OL}	0	-	0.8	V	3

Notes:

1. Internally AC coupled, but requires a external 100Ω differential load termination.
2. 20–80%.
3. LOS is an open collector output. Should be pulled up with 4.7KΩ on the host board.

Transmitter Optical Characteristics

Table 6. Transmitter Optical Characteristics

Parameter	Symbol	Minimum	Typical	Maximum	Unit	Notes
Launch Optical Power	P_o	-1	-	+3.0	dBm	1
Center Wavelength Range	λ_c	1464.5	-	1617.5	nm	-
Center Wavelength Tolerance	$\Delta\lambda_c$	-6.5		6.5	nm	
Extinction Ratio	EX	8.2	-	-	dB	2
Optical Modulation Amplitude	OMA	-2.1	-	-	dBm	
Side Mode Suppression Ratio	SMSR	30	-	-	dB	-
Transmitter and Dispersion Penalty @800ps/nm	TDP	-	-	2.0	dB	-
Relative Intensity Noise	RIN			-128	dB/Hz	
Optical Return Loss Tolerance	ORLT	-	-	21	dB	-
Pout @TX-Disable Asserted	P_{off}	-	-	-30	dBm	1
Eye Diagram	IEEE Std 802.3-2005 10Gb Ethernet 10GBASE-ER compatible					

Notes:

1. The optical power is launched into 9/125μm SMF.
2. Measured with a PRBS 2³¹-1 test pattern @10.3125Gbps.

Receiver Optical Characteristics

Table 7. Receiver Optical Characteristics

Parameter	Symbol	Minimum	Typical	Maximum	Unit	Notes
Center Wavelength	λ_c	1464.5	-	1617.5	nm	-
Receiver Sensitivity (P_{avg})	S	-	-	-15.8	dBm	1
Receiver Sensitivity (OMA)	S_{OMA}	-	-	-14.1	dBm	1
Receiver Overload (P_{avg})	P_{OL}	-1.0	-	-	dBm	1
Stressed Sensitivity (OMA)	-	-	-	-11.3	dBm	2
Optical Return Loss	ORL	26	-	-	dB	-
LOS De-Assert	LOS_D	-	-	-17	dBm	-
LOS Assert	LOS_A	-30	-	-	dBm	-
LOS Hysteresis	-	0.5	-	-	dB	-

Notes:

1. Measured with PRBS 2³¹-1 test pattern, 10.3125Gb/s, BER<10⁻¹².
2. Comply with IEEE 802.3-2005.

Recommended Host Board Power Supply Filter Network

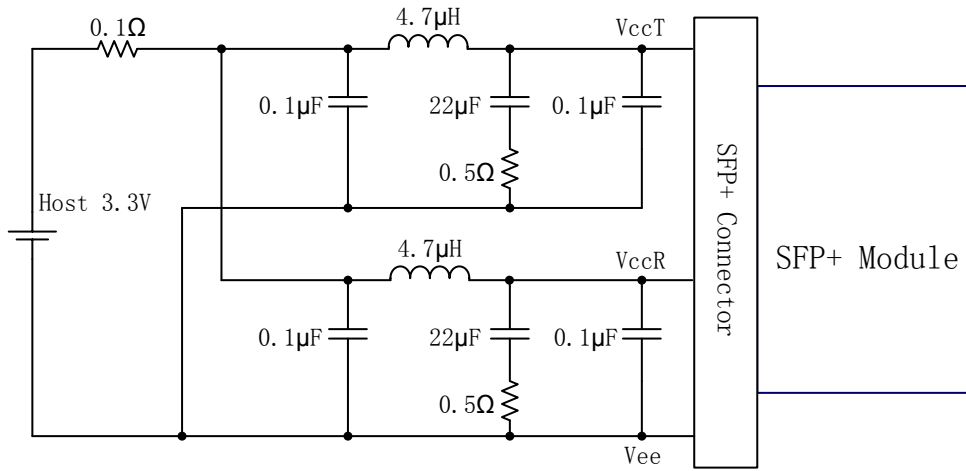

Figure 2. Recommended Host Board Power Supply Filter Network

Recommended Application Interface Block Diagram

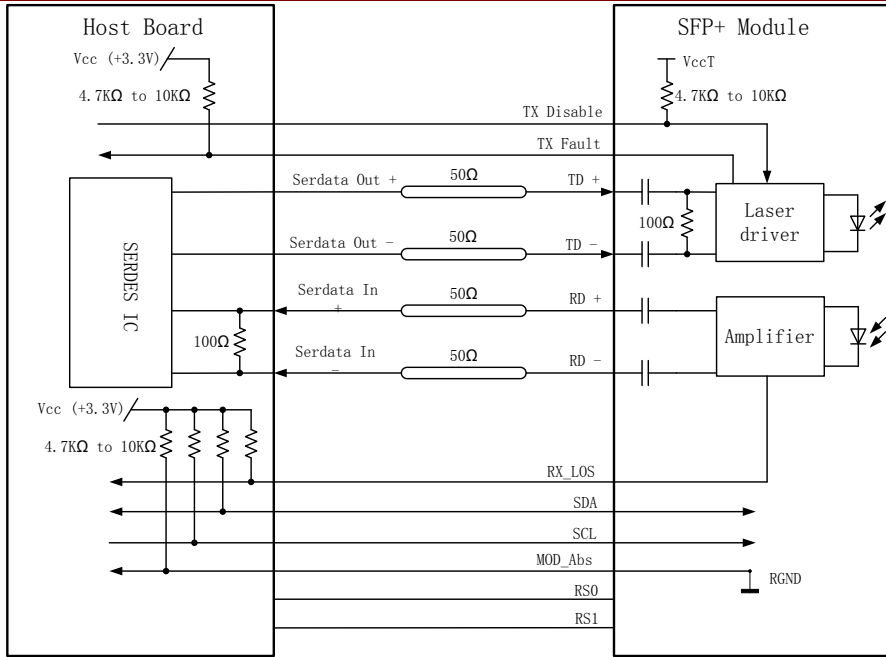

Figure 3. Recommended Application Interface Block Diagram

Mechanical specifications

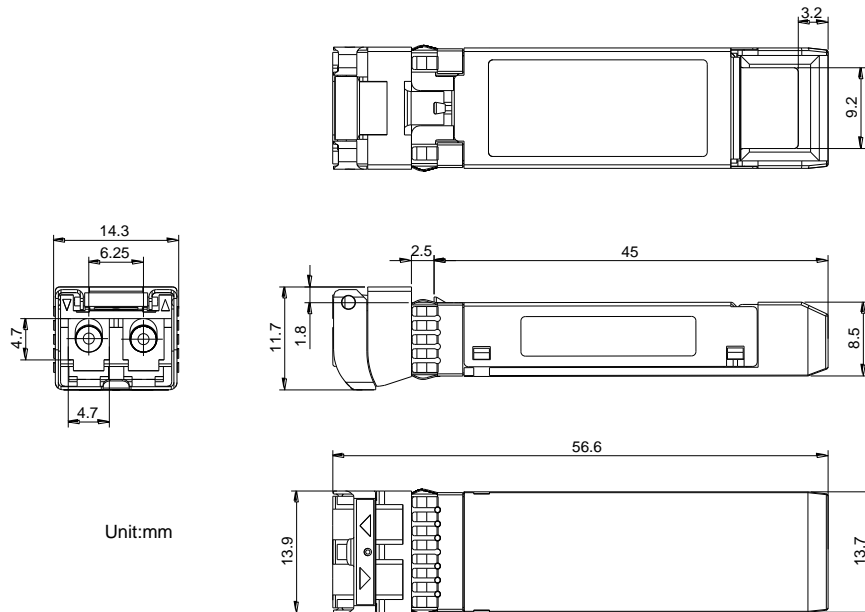

Figure 4. Outline Drawing

PCB layout recommendation

- Notes:
1. Datum and basic dimensions established by customer
 2. Pads and vias are chassis ground, 11 places
 3. Thru holes, plating optional

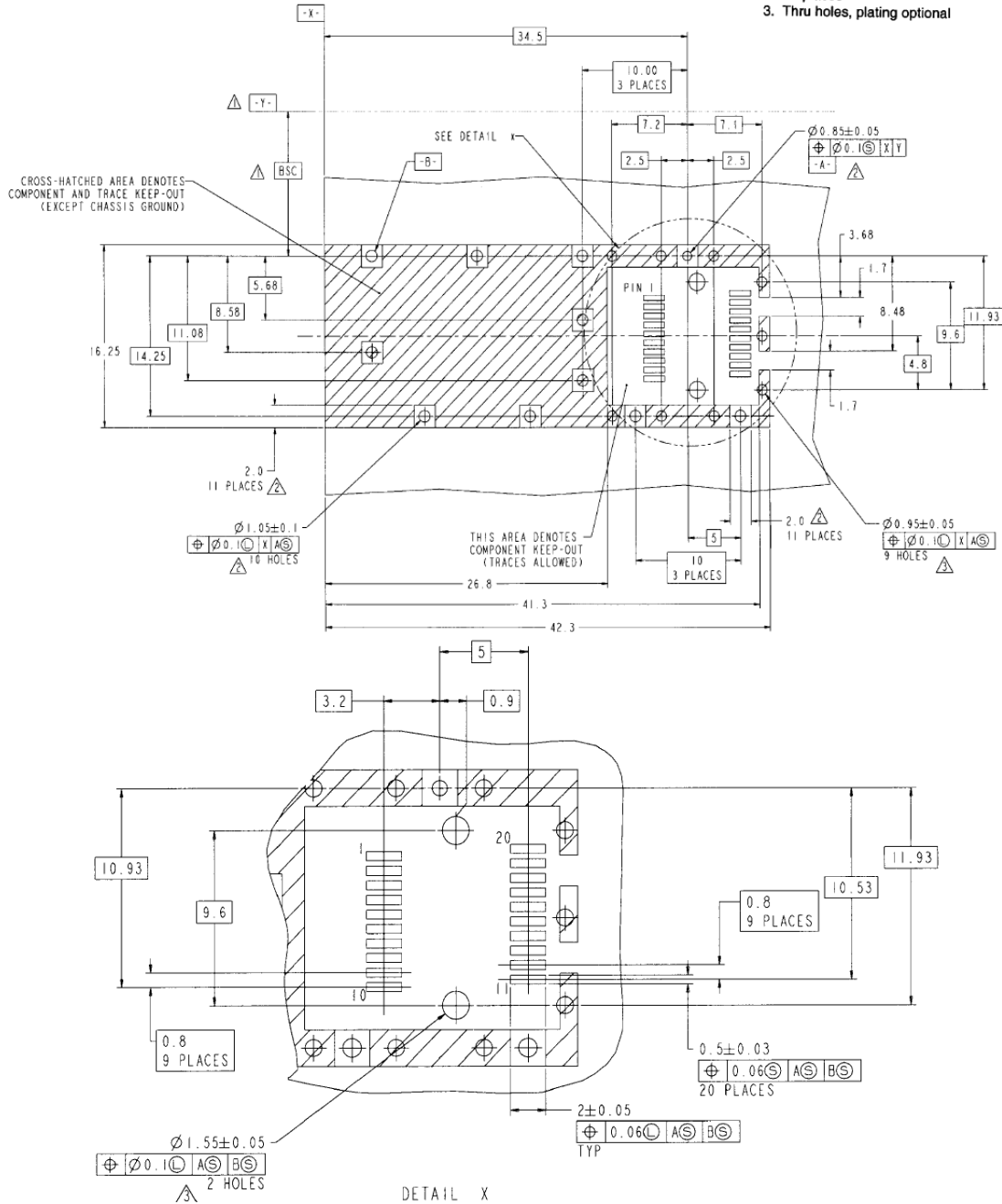

Figure 5. PCB layout recommendation

For More Information

Linktel Technologies Co., Ltd



LX431xCDR
10GEthernet 40km CWDM SFP+ Transceiver
10GBASE-ER / 10GBASE-EW

sales@linkteltech.com

<http://www.linkteltech.com>

Linktel China

No.20 University Science Park Road,East-lake Hi-tech Development Zone, Wuhan, 430223, China

Tel: +86 27-87929302

Linktel USA

3311 Ingersoll Cout,San Jose,CA 95148

Tel: +1(408)833-9142

linktelus@linkteltech.com