



**RoHS compliant**  
**TX-1550/RX-1310 nm Multi-mode Bi-directional (Single-Fiber) 2km**  
**SFP LC Simplex Connector**  
**155 Mbps ATM /Fast Ethernet**



### Features

- RoHS compliant
- Fast Ethernet application
- Industry standard small form pluggable (SFP) package
- Simplex LC connector
- Differential LVPECL inputs and outputs
- Single power supply 3.3V
- TTL signal detect indicator
- Hot Pluggable
- Class 1 laser product complies with EN 60825-1

### Ordering Information

PART NUMBER	TX/RX	INPUT/OUTPUT	SIGNAL DETECT	TEMPERATURE	LD Type	Distance
LM48-A3S-TI-N-B5	1550/1310	AC/AC	TTL	-40 °C to 85 °C	1550 FP	2km
LM48-A3S-TC-N-B5	1550/1310	AC/AC	TTL	0 °C to 70 °C	1550 FP	2km

### Absolute Maximum Ratings

PARAMETER	SYMBOL	MIN	MAX	UNITS	NOTE
Storage Temperature	$T_S$	-40	85	°C	
Supply Voltage	$V_{CC}$	-0.5	4.0	V	
Input Voltage	$V_{IN}$	-0.5	$V_{CC}$	V	
Output Current	$I_o$	---	50	mA	
Operating Current	$I_{OP}$	---	400	mA	



RoHS compliant  
**TX-1550/RX-1310 nm Multi-mode Bi-directional (Single-Fiber) 2km**  
**SFP LC Simplex Connector**  
**155 Mbps ATM /Fast Ethernet**

### Recommended Operating Conditions

PARAMETER	SYMBOL	MIN	MAX	UNITS	NOTE
Case Operating Temperature	$T_C$	0	70	°C	LM48-A3S-TC-N-B5
		-40	85	°C	LM48-A3S-TI-N-B5
Supply Voltage	$V_{CC}$	3.1	3.5	V	
Supply Current	$I_{TX} + I_{RX}$	---	200	mA	

### Transmitter Electro-optical Characteristics

$V_{CC} = 3.1 \text{ V to } 3.5 \text{ V}, T_C = 0^\circ \text{C to } 70^\circ \text{C} (-40^\circ \text{C to } 85^\circ \text{C})$

PARAMETER	SYMBOL	MIN	TYP.	MAX	UNITS	NOTE
Output Optical Power 50/125, 62.5/125 $\mu\text{m}$ fiber	$P_{out}$	-10	---	0	dBm	Average
Extinction Ratio	$ER$	8.2	---	---	dB	
Center Wavelength	$\lambda_C$	1480	1520	1580	nm	
Spectral Width (RMS)	$\Delta\lambda$	---	---	7	nm	
Rise/Fall Time (10–90%)	$T_{r,f}$	---	1	2	ns	
Output Eye	Compliant with Telcordia GR-253-CORE Issue 3 and ITU-T recommendation G-957					
Max. $P_{out}$ TX-DISABLE Asserted	$P_{OFF}$	---	---	-45	dBm	
Differential Input Voltage	$V_{DIFF}$	0.4	---	2.0	V	



**RoHS compliant**  
**TX-1550/RX-1310 nm Multi-mode Bi-directional (Single-Fiber) 2km**  
**SFP LC Simplex Connector**  
**155 Mbps ATM /Fast Ethernet**

**Receiver Electro-optical Characteristics**

$V_{CC} = 3.1\text{ V to }3.5\text{ V}$ ,  $T_C = 0\text{ }^\circ\text{C to }70\text{ }^\circ\text{C}$  ( $-40\text{ }^\circ\text{C to }85\text{ }^\circ\text{C}$ )

PARAMETER	SYMBOL	MIN	TYP.	MAX	UNITS	NOTE
Optical Input Power-maximum	$P_{IN}$	0	---	---	dBm	BER < $10^{-10}$
Optical Input Power-minimum (Sensitivity)	$P_{IN}$	---	---	-28	dBm	BER < $10^{-10}$
Operating Center Wavelength	$\lambda_C$	1260	---	1360	nm	
Optical isolation	ISO	---	---	-40	dB	$\lambda=1480\sim1600\text{nm}$
Loss of signal-Asserted	$P_A$	---	---	-28	dBm	
Loss of signal-Deasserted	$P_D$	-45	---	---	dBm	
Differential Output Voltage	$V_{DIFF}$	0.5	---	1.6	V	
Data Output Rise, Fall Time (10%~90%)	$T_{r,f}$	---	1	2	ns	
Receiver Loss of Signal Output Voltage-Low	$RX\_LOS_L$	0	---	0.5	V	
Receiver Loss of Signal Output Voltage-High	$RX\_LOS_H$	2.4	---	$V_{CC}$	V	

### Block Diagram of Transceiver

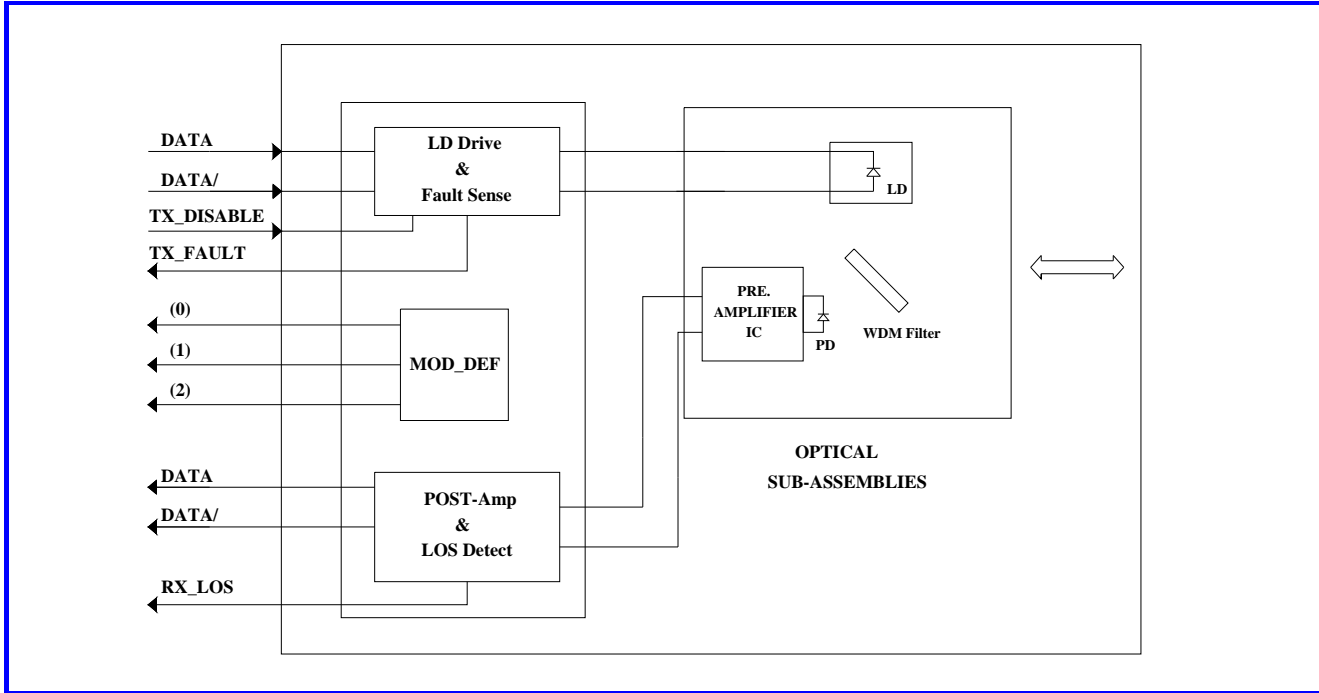

#### Transmitter and Receiver Optical Sub-assembly Section

A 1550 nm InGaAsP laser and an InGaAs PIN photodiode integrate with an WDM filter to form a bi-directional single fiber optical subassembly (OSA). The laser of OSA is driven by a LD driver IC which converts differential input LVPECL logic signals into an analog laser driving current. And, The photodiode of OSA is connected to a circuit providing post-amplification quantization, and optical signal detection.

#### TX\_DISABLE

The TX\_DISABLE signal is high (TTL logic “1”) to turn off the laser output.

#### Receive Loss (RX\_LOS)

The RX\_LOS is high (logic “1”) when there is no incoming light from the companion transceiver. This signal is normally used by the system for the diagnostic purpose. The signal is operated in TTL level.



RoHS compliant  
TX-1550/RX-1310 nm Multi-mode Bi-directional (Single-Fiber) 2km  
SFP LC Simplex Connector  
155 Mbps ATM /Fast Ethernet

### Dimensions

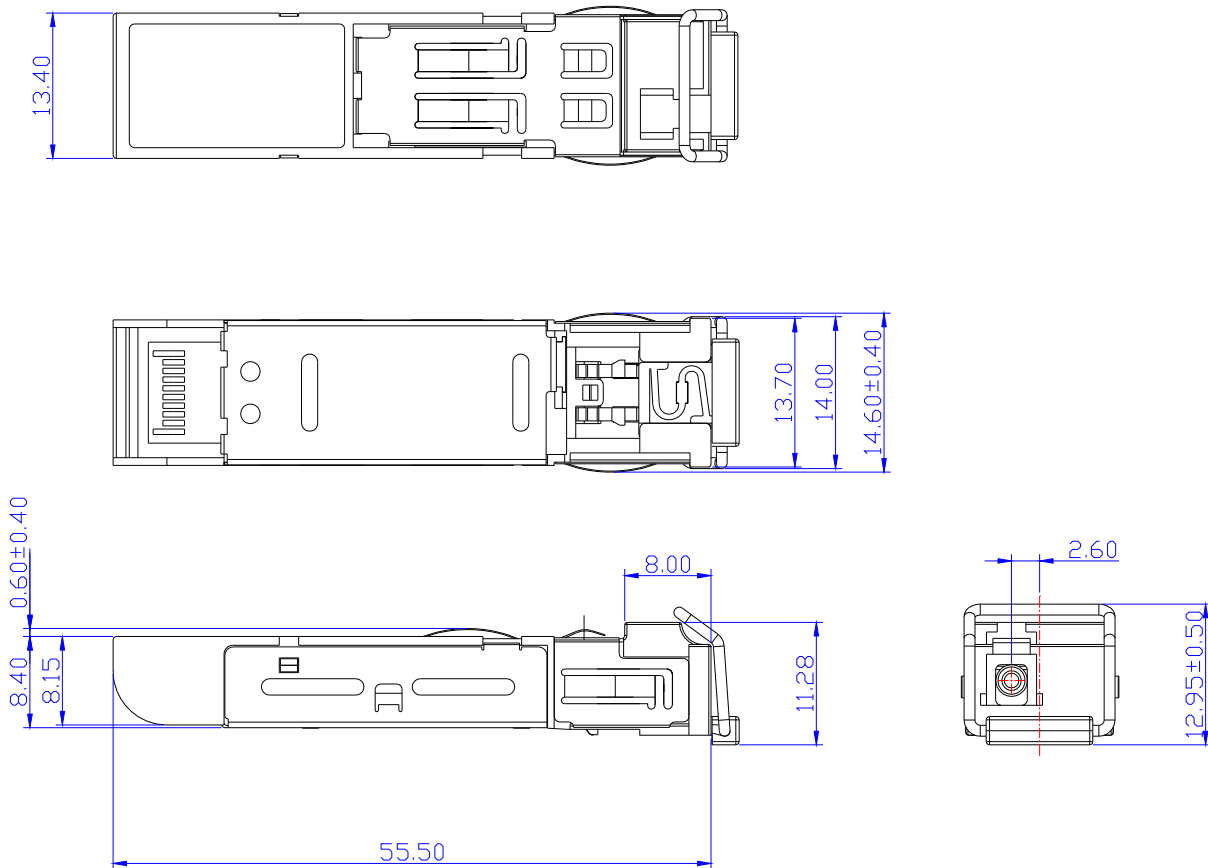

**DIMENSIONS ARE IN MILLIMETERS**

**ALL DIMENSIONS ARE ±0.2mm UNLESS OTHERWISE SPECIFIED**

**SFP host board mechanical layout**

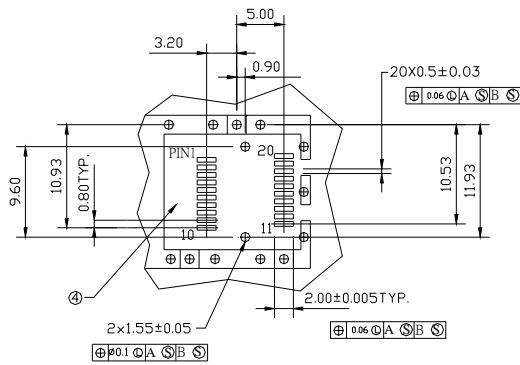
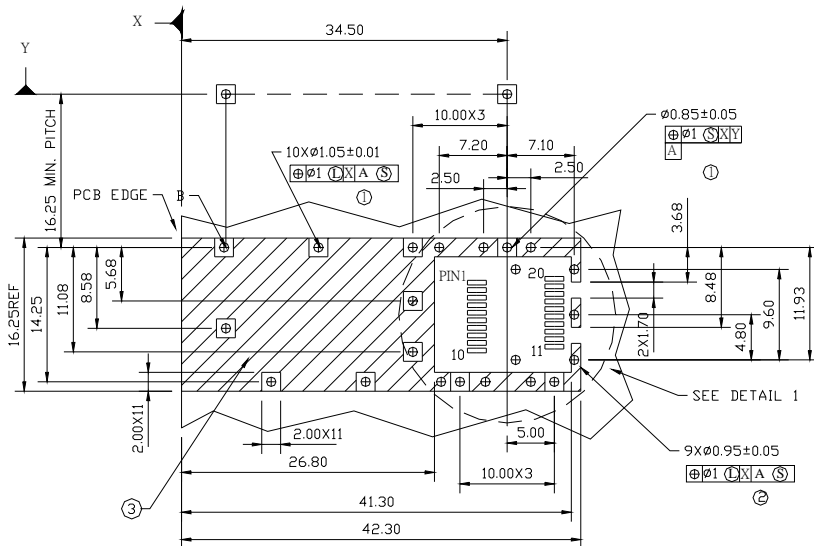

DETAIL 1

**LEGEND**

- 1.PADS AND VIAS ARE CHASSIS GROUND
- 2.THROUGH HOLES, PLATING OPTIONAL
- 3.HATCHED AREA DENOTES COMPONENT AND TRACE KEEPOUT(EXCEPT CHASSIS GROUND)
- 4.AREA DENOTES COMPONENT KEEPOUT (TRACES ALLOWED)

DIMENSIONS ARE IN MILLIMETERS

Unit: mm



RoHS compliant  
TX-1550/RX-1310 nm Multi-mode Bi-directional (Single-Fiber) 2km  
SFP LC Simplex Connector  
155 Mbps ATM /Fast Ethernet

Assembly drawing

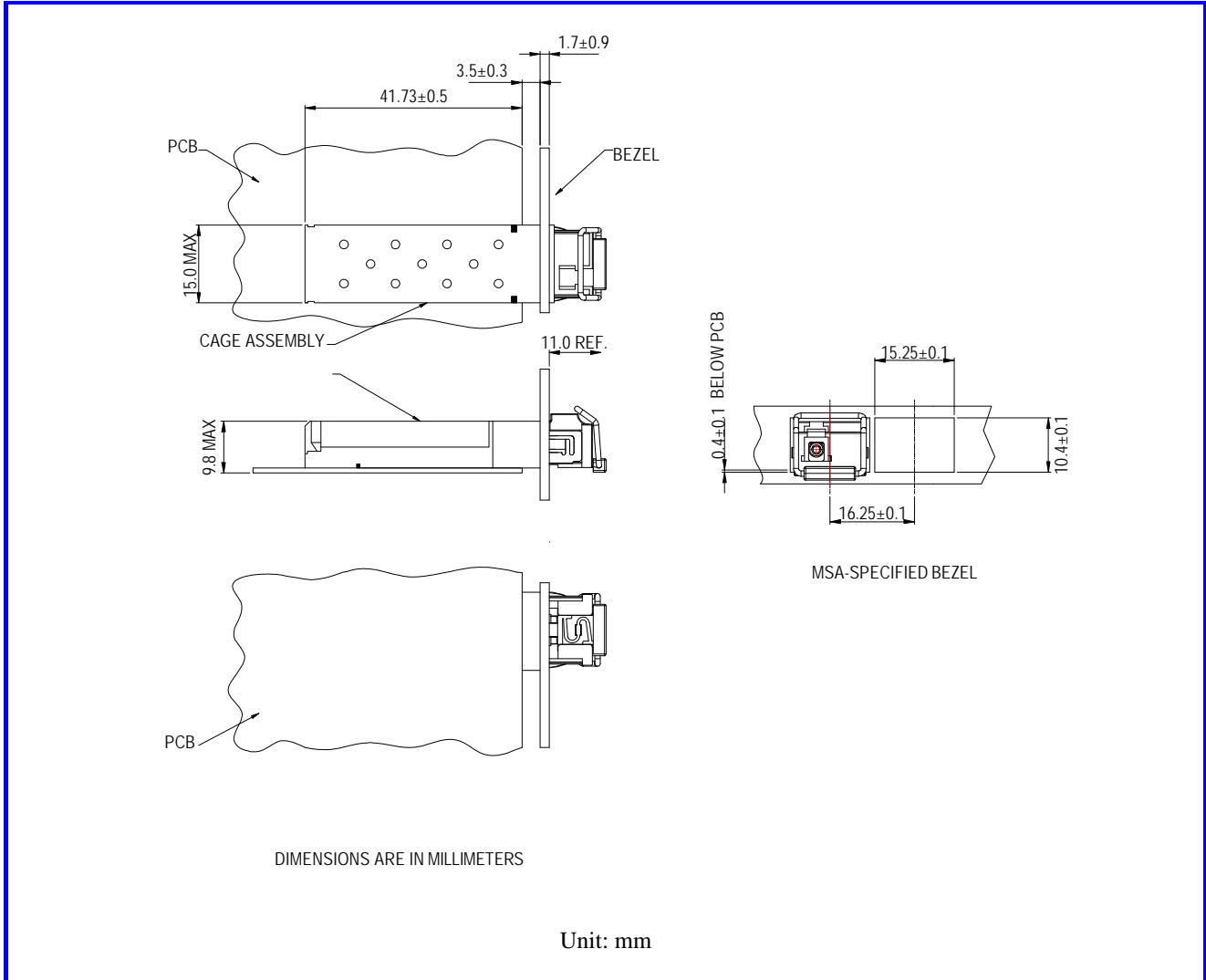



RoHS compliant  
 TX-1550/RX-1310 nm Multi-mode Bi-directional (Single-Fiber) 2km  
 SFP LC Simplex Connector  
 155 Mbps ATM /Fast Ethernet

**Pin Assignment**

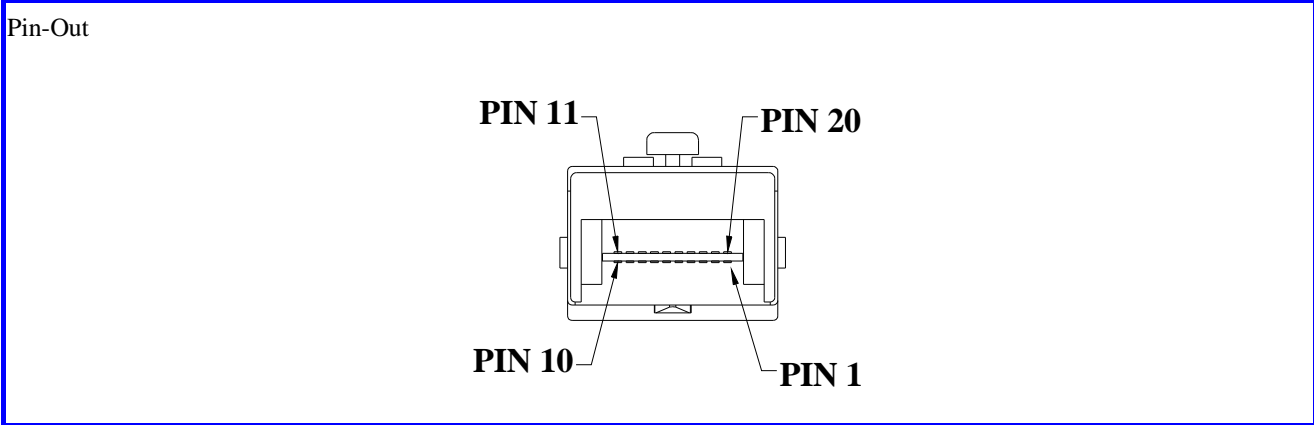

Pin	Signal Name	Description
1	$T_{GND}$	Transmit Ground
2	$TX\_FAULT$	Transmit Fault
3	$TX\_DISABLE$	Transmit Disable
4	$MOD\_DEF (2)$	SDA Serial Data Signal
5	$MOD\_DEF (1)$	SCL Serial Clock Signal
6	$MOD\_DEF (0)$	TTL Low
7	$RATE\_SELECT$	Open Circuit
8	$RX\_LOS$	Receiver Loss of Signal, TTL High, open collector
9	$R_{GND}$	Receiver Ground
10	$R_{GND}$	Receiver Ground
11	$R_{GND}$	Receiver Ground
12	$RX-$	Receive Data Bar, Differential PECL, ac coupled
13	$RX+$	Receive Data, Differential PECL, ac coupled
14	$R_{GND}$	Receiver Ground
15	$V_{CCR}$	Receiver Power Supply
16	$V_{CCT}$	Transmitter Power Supply
17	$T_{GND}$	Transmitter Ground
18	$TX+$	Transmit Data, Differential PCEL, ac coupled
19	$TX-$	Transmit Data Bar, Differential PCEL, ac coupled
20	$T_{GND}$	Transmitter Ground





**RoHS compliant**  
**TX-1550/RX-1310 nm Multi-mode Bi-directional (Single-Fiber) 2km**  
**SFP LC Simplex Connector**  
**155 Mbps ATM /Fast Ethernet**

---

### **Eye Safety Mark**

The LM4 series single mode transceiver is a class 1 laser product. It complies with EN 60825-1 and FDA 21 CFR 1040.10 and 1040.11. In order to meet laser safety requirements the transceiver shall be operated within the Absolute Maximum Ratings.

**Caution**

**All adjustments have been done at the factory before the shipment of the devices. No maintenance and user serviceable part is required. Tampering with and modifying the performance of the device will result in voided product warranty.**

**Required Mark**

Class 1 Laser Product  
Complies with  
21 CFR 1040.10 and 1040.11

Note : All information contained in this document is subject to change without notice.